

CPD-100ES

SERVICE MANUAL

CPD-100ES
Southern Hemisphere Model
Equator Model

Chassis No. SCC-L15B-A



X2R CHASSIS

SPECIFICATIONS

Picture Tube	0.25 mm aperture grill pitch 15 inches measured diagonally 90-degree deflection	Standard image area	Approx. 270 x 202 mm (w/h) (10 ^{3/4} x 8 inches)
Video image area	(14" maximum viewing image) Approx. 284 x 212 mm (w/h) (11 ^{1/4} x 8 ^{3/8} inches)	Deflection frequency	Horizontal: 30 to 70 KHz Vertical: 50 to 120 Hz
Logical resolution	Horizontal: Max. 1280 dots Vertical: Max. 1024 lines	AC input voltage / current	100 to 120 V, 50-60 Hz, 1.8 A 220 to 240 V, 50-60 Hz, 1.0 A
Physical resolution	Horizontal: Max. 1024 dots Vertical: Max. 768 lines	Dimensions	368 x 373 x 384.5 mm (w/h/d) (14 ^{1/2} x 14 ^{3/4} x 15 ^{1/4} inches)
		Mass	Approx. 14.0kg (30 lb 14 oz)

Design and specifications are subject to change without notice.



TRINITRON® COLOR COMPUTER DISPLAY
SONY®

POWER SAVING FUNCTION

This monitor meets the power saving guidelines set by the EPA Energy Star Program as well as the more stringent TC092 guidelines (NUTEK). It is capable of reduced power consumption when used with a computer equipped with Display Power Management Signaling (DPMS). By sensing the absence of the sync signal coming from the computer, it will reduce the power consumption as follows:

CAUTION: The Power Saving function will automatically put the monitor into Active-off state if the power switch is turned on without any video signal input. Once the horizontal and vertical syncs are sensed, the monitor will automatically return to its Normal operation state.

	State	Power consumption	Required resumption time	⏻ Power indicator
1	Normal Operation	≤110 W	————	green on
2	Suspend (1st step of power saving)	≤15 W	approx. 3 sec.	orange and green flashes alternately
3	Active-off (2nd step of power saving)	≤15 W	approx. 10 sec.	orange and green flashes alternately
4	Active-off (3rd step of power saving)	≤8 W	approx. 10 sec.	orange on
5	Power - Off	0 W	————	off

TIMING SPECIFICATION

Mode	1	2	3	4	5	6	7	8	9	
Resolution(H x V) Dot Clock(MHz)	640 x 480 25.175	640 x 480 36.000	800 x 600 49.500	800 x 600 56.250	832 x 624 57.283	1024 x 768 78.750	1024 x 768 94.500	1280 x 1024 108.000	720 x 400 28.322	
Horizontal										
Hor. Freq. (kHz)	31.469	43.269	46.875	53.674	49.725	60.023	68.677	63.981	31.469	
H-Total	31.778	23.111	21.333	18.631	20.111	16.660	14.561	15.630	31.777	
H-Blanking	6.356	5.333	5.172	4.409	5.586	3.657	3.725	3.778	6.355	
H-Front Porch	0.636	1.556	0.323	0.569	0.559	0.203	0.508	0.444	0.636	
H-Sync.	3.813	1.556	1.616	1.138	1.117	1.219	1.016	1.037	3.813	
H-Back Porch	1.907	2.222	3.232	2.702	3.910	2.235	2.201	2.296	1.907	
H-Active (μsec)	25.422	17.778	16.162	14.222	14.524	13.003	10.836	11.852	25.422	
Vertical										
Ver. Freq. (Hz)	59.940	85.008	75.000	85.061	74.550	75.029	84.997	60.020	70.087	
V-Total	525	509	625	631	667	800	808	1066	449	
V-Blanking	45	29	25	31	43	32	40	42	49	
V-Front Porch	10	1	1	1	1	1	1	1	12	
V-Sync.	2	3	3	3	3	3	3	3	2	
V-Back Porch	33	25	21	27	39	28	36	38	35	
V-Active (lines)	480	480	600	600	624	768	768	1024	400	
Sync.										
INT(G) EXT (H/V)/POLARITY EXT (CS)/POLARITY INT/NON INT	NO YES -/ NO NON INT	NO YES -/ NO NON INT	NO YES +/ NO NON INT	NO YES +/ NO NON INT	NO YES -/ NO NON INT	NO YES +/ NO NON INT	NO YES +/ NO NON INT	NO YES +/ NO NON INT	NO YES +/ NO NON INT	NO YES -/ NO NON INT

TABLE OF CONTENTS

<u>Section</u>	<u>Title</u>	<u>Page</u>
1. GENERAL		4
2. DISASSEMBLY		
2-1.	Cabinet Removal	7
2-2.	Service Position	7
2-3.	D Board Removal	7
2-4.	Picture Tube Removal	8
3. SAFETY RELATED ADJUSTMENT		9
4. ADJUSTMENTS		10
5. DIAGRAMS		
5-1.	BlockDiagram	15
5-2.	Circuit Boards Location	18
5-3.	Schematic Diagrams and Printed Wiring Boards	18
1.	D Board - Schematic Diagram	19
2.	A Board - Schematic Diagram	23
5-4.	Semiconductors	27
6. EXPLODED VIEWS		
6-1.	Chassis	29
6-2.	Packing Materials	30
7. ELECTRICAL PARTS LIST		31

The operating instructions mentioned here are partial abstracts from the Operating Instruction Manual. The page numbers of the Operating Instruction Manual remain as in the manual.

Getting Started

Before using this monitor, please make sure that the following items are included in your package: Multiscan 100ES/200ES monitor (1), power cord (1), warranty card (1), "Windows95 Monitor Information Disk" (1), and this operating instruction manual (1).

This monitor will sync with any IBM or compatible system equipped with VGA or greater graphics capability. Although this monitor will sync to other platforms running at horizontal frequencies between 30 and 70 kHz, including Macintosh and Power Macintosh system, a cable adapter is required. Please consult your dealer for advice on which adapter is suitable for your needs.

Step 1: With the computer switched off, attach the video signal cable to the video output.

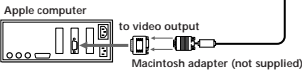
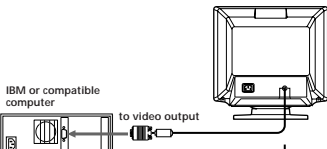

Step 2: Attach the power cord to the monitor and the other end to a power outlet.

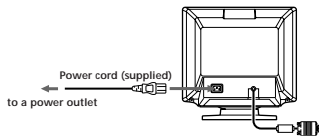

Step 3: Turn on the monitor and computer.

Step 4: If necessary, adjust the user controls according to your personal preference.

The installation of your Multiscan 100ES/200ES is complete. Enjoy your monitor.

- 1) VGA is a trademark of IBM Corporation.
- 2) VESA is a trademark of the non-profit organization, Video Electronics Standard Association.
- 3) Macintosh is a trademark of Apple Computer Inc.
- 4) Windows® is a registered trademark of Microsoft Corporation in the United States and other countries.

Using Your Monitor

Preset and User Modes

The Multiscan 100ES/200ES has factory preset modes for the 8 most popular industry standards for true "plug and play" capability. For less common modes, the Multiscan 100ES/200ES's Digital Multiscan Technology will perform all of the complex adjustments necessary to ensure a high quality picture for any timing between 30 and 70 kHz.

No.	Resolution (dots x lines)	Horizontal Frequency	Vertical Frequency	Graphics Mode
1	640 x 480	31.5 kHz	60 Hz	VGA Graphic ¹⁾
2	640 x 480	43.3 kHz	85 Hz	VESA ²⁾
3	800 x 600	46.9 kHz	75 Hz	VESA ²⁾
4	800 x 600	53.7 kHz	85 Hz	VESA ²⁾
5	832 x 624	49.7 kHz	75 Hz	Macintosh 16" Color ²⁾
6	1024 x 768	60.0 kHz	75 Hz	VESA ²⁾
7	1024 x 768	68.7 kHz	85 Hz	VESA ²⁾
8	1280 x 1024	64.0 kHz	60 Hz	VESA ²⁾

For the customers using the Windows®95
Install the new model information of the Sony computer display from "Windows95 Monitor Information Disk" into your PC. (To install the file, refer to the attached "About the Windows95 Monitor Information Disk/File".)

This monitor complies with "VESA DDC", the standards of Plug&Play. If your PC /graphic board complies with DDC, select "Plug and Play Monitor (VESA DDC)" or this monitor's model name (CPD-100ES/100EST or CPD-200ES/200EST) as "Monitor type" from "Control Panel" on Windows95. Some PC /graphic boards do not comply with DDC. Even if they comply with DDC, they may have some problems on connecting to this monitor. In this case, select this monitor's model name (CPD-100ES/100EST or CPD-200ES/200EST) as "Monitor type" on Windows95.

Recommended horizontal timing conditions
Horizontal sync width should be: >1.0 μsec.
Horizontal blanking width should be: >3.0 μsec. (Multiscan 100ES)/ >3.0 μsec. (Multiscan 200ES).
Vertical sync width should be: < 560 μsec.

Note
CPD-100ES/100EST and CPD-200ES/200EST does not apply to Macintosh 21" color mode.

SECTION 1 GENERAL

Adjustments

When one of the preset-type signals is input, no picture adjustment is necessary. You can, however, adjust the picture to your preferences by following the procedure described below. You can adjust all items on the OSD (On Screen Display).

- Before adjusting the items, turn on the unit and feed the video signal from the connected computer/work station.
- Adjustments will be stored automatically.

Control Panel



Adjusting the Picture Contrast

The adjustment data becomes the common setting for all input signals.

- 1 Press the ◀/▶ button. The "BRIGHTNESS/CONTRAST" OSD appears.

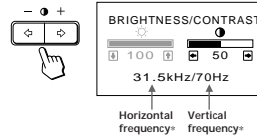

- 2 Press the ◀/▶ buttons to adjust picture contrast.
 - ▶ ... for more contrast
 - ◀ ... for less contrast

The "BRIGHTNESS/CONTRAST" OSD disappears 3 seconds after you release the buttons.

To reset, press the RESET button while the OSD is on.

Adjusting the Picture Brightness

The adjustment data becomes the common setting for all input signals.

- 1 Press the ☀/☿ button. The "BRIGHTNESS/CONTRAST" OSD appears.

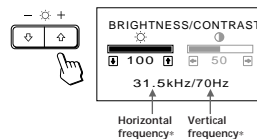

- 2 Press the ☀/☿ buttons to adjust picture brightness.
 - ☀ ... for less brightness
 - ☿ ... for more brightness

The "BRIGHTNESS/CONTRAST" OSD disappears 3 seconds after you release the buttons.

To reset, press the RESET button while the OSD is on.

Adjusting the Picture Centering

The adjustment data becomes the individual setting for each input signal received.

- 1 Press the CENTER button. The "CENTER" OSD appears.

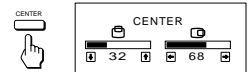

- 2 For vertical adjustment Press the ▲/▼ buttons.



▲ ... to move up
▼ ... to move down

For horizontal adjustment Press the ◀/▶ buttons.



◀ ... to move left
▶ ... to move right

To erase the "CENTER" OSD, press the CENTER button again. The "CENTER" OSD automatically disappears 10 seconds after you release the buttons.

To reset, press the RESET button while the OSD is on.

* The horizontal and vertical frequencies for each input signal received appear on the "BRIGHTNESS/CONTRAST" OSD.

Adjustments

Adjusting the Picture Size

The adjustment data becomes the individual setting for each input signal received.

- 1 Press the SIZE button.
The "SIZE" OSD appears.

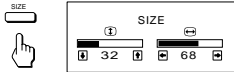

- 2 For vertical adjustment
Press the \uparrow/\downarrow buttons.



\uparrow ... to enlarge
 \downarrow ... to diminish

For horizontal adjustment
Press the \leftarrow/\rightarrow buttons.



\leftarrow ... to diminish
 \rightarrow ... to enlarge

To erase the "SIZE" OSD, press the SIZE button again.
The "SIZE" OSD automatically disappears 10 seconds after you release the buttons.

To reset, press the RESET button while the OSD is on.

Adjusting the Picture Rotation

The adjustment data becomes the common setting for all input signals.

- 1 Press the GEOM button.
The "GEOMETRY" OSD appears.

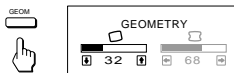

- 2 Press the \odot/\oplus buttons.
 \uparrow ... to rotate clockwise
 \downarrow ... to rotate counterclockwise



To erase the "GEOMETRY" OSD, press the GEOM button again.
The "GEOMETRY" OSD automatically disappears 10 seconds after you release the buttons.

To reset, press the RESET button while the OSD is on.

Adjusting the Pincushion

The adjustment data becomes the individual setting for each input signal received.

- 1 Press the GEOM button.
The "GEOMETRY" OSD appears.

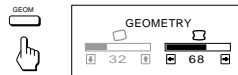

- 2 Press the \leftarrow/\rightarrow buttons.



\leftarrow ... to diminish the picture sides

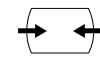

\rightarrow ... to expand the picture sides

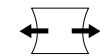

To erase the "GEOMETRY" OSD, press the GEOM button again.
The "GEOMETRY" OSD automatically disappears 10 seconds after you release the buttons.

To reset, press the RESET button while the OSD is on.

Setting the Color Temperature

The selected color temperature becomes the common setting for all input signals.

- 1 Press the COLOR button.
The "COLOR TEMPERATURE" OSD appears.

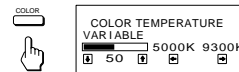

- 2 Adjust with the \leftarrow/\rightarrow and \odot/\oplus buttons.

To select 5000K or 9300K

Press the \leftarrow/\rightarrow buttons.
The selected color temperature is indicated in yellow.



\leftarrow ... to select 5000K
 \rightarrow ... to select 9300K

To obtain the desired color temperature between 5000K and 9300K
Press the \odot/\oplus buttons.



\uparrow ... for higher temperature
 \downarrow ... for lower temperature

Your most recent adjusted color temperature will be recalled by pressing the \odot/\oplus button.

To erase the "COLOR TEMPERATURE" OSD, press the COLOR button again.
The "COLOR TEMPERATURE" OSD automatically disappears 10 seconds after you release the buttons.

To reset, press the RESET button while the OSD is on.

Resetting the Adjustment Data to Factory-preset Levels

To reset an adjustment item

Press the button of the adjustment item you want to reset, and then press the RESET button before the OSD (On Screen Display) disappears.

To reset all adjustment data at once (for the received signal)

Press the RESET button when no OSD is shown.



To reset all adjustment data to factory-preset levels

Press and hold the RESET button for more than 2 seconds. All adjustment data are reset to factory-preset levels.



Entering New Timings

When using a video mode that is not one of the factory preset modes, some fine tuning may be required to optimize the display to your preferences. Simply adjust the monitor according to the preceding adjustment instructions. The adjustments will be stored automatically and recalled whenever that mode is used. A total of 8 user-defined modes can be stored in memory. If the 9th mode is entered, it will replace the first.

Power Saving Function

This monitor meets the power saving guidelines set by the International ENERGY STAR Program as well as the more stringent TCO92 803299 (NUTEK) guidelines. It is capable of reduced power consumption when used with a computer equipped with Display Power Management Signaling (DPMS). By sensing the absence of the sync signal coming from the computer, it will reduce the power consumption as follows:

CAUTION: The Power Saving function will automatically put the monitor into Active-off state if the power switch is turned on without any video signal input. Once the horizontal and vertical syncs are sensed, the monitor will automatically return to its Normal operation state.

State	Power consumption	Required resumption time	POWER indicator
1 Normal operation	≤ 110 W	—	green on
2 Stand-by (1st step of power saving)	≤ 15 W	approx. 3 sec.	Orange and green flashes alternately
3 Suspend (2nd step of power saving)	≤ 15 W	approx. 3 sec.	Orange and green flashes alternately
4 Active-off (3rd step of power saving)	≤ 8 W	approx. 10 sec.	Orange on
5 Power-off	0 W	—	off

Plug and Play

This monitor complies with DDC™1 and DDC2B, which are the Display Data Channel (DDC) standards of VESA. When a DDC1 host system is connected, the monitor synchronizes with the V. CLK in accordance with the VESA standards and outputs the EDID (Extended Display Identification Data) to the data line. When a DDC2B host system is connected, the monitor automatically switches to the DDC2B communication.

DDC™ is a trademark of the Video Electronics Standard Association.

Use of the Tilt-Swivel

With the tilt-swivel, this unit can be adjusted to be viewed at your desired angle within 180° horizontally and 20° vertically. To turn the unit vertically and horizontally, hold it at its bottom with both hands.

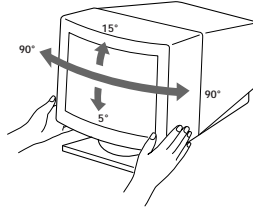

Damper Wire

Using a white background, very thin horizontal stripes on the screen are visible as shown on the illustration. These stripes are damper wires. These wires are attached to the aperture grille inside the Trinitron tube and are there to dampen vibrations of the aperture grille in order to prevent them from influencing the picture quality.

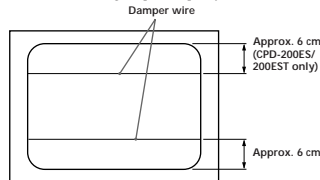

Troubleshooting

This section may help you isolate a problem and as a result, eliminate the need to contact technical support, allowing continued productivity.

No picture

- If the POWER indicator is not lit.
 - Check that the power cord is properly connected.
 - Check that the POWER switch is in the "ON" position.
- If the POWER indicator is flashing in green and orange alternately.
 - Check that your computer power switch is in the "ON" position.
 - The monitor will recover when you press any key on the keyboard of the computer.
 - Check that the video cable is properly connected.
 - Ensure that no pins are bent or pushed in the HD15 connector of the cable.
 - Check that the video card is seated completely in a proper bus slot.
 - Check that the video sync signal is within that specified for the monitor.
 - If using a Macintosh system, check that a proper HD15-D15 adapter is provided to work correctly with your Macintosh.
 - The monitor has a self-diagnose function. After disconnecting the video signal cable from the computer, turn on the POWER switch of the monitor. Press and hold the "+" side of the button for 2 seconds, then color bars will appear. The monitor is operating normally if the red, green, and blue color bars appear. Contact the maker of the computer to which the monitor is connected.
- If the POWER indicator is flashing.
 - There is a potential monitor failure. Contact your dealer.

If the message of "OUT OF SCAN RANGE" appears on the screen

- Check that the video sync signal is specified for the monitor.

Picture is scrambled

- Check your graphics board manual for the proper monitor setting on your Multiscan 100ES/200ES.
- Check this manual and confirm that the graphic mode and the frequency at which you are trying to operate is supported. Even within the proper range some video boards may have a sync pulse that is too narrow for the monitor to sync correctly.

Color is not uniform

- If the monitor is close to any potential sources of magnetic fields such as a speaker, or you turn the monitor while the POWER switch is in the "ON" position, color may not be uniform. Trip the POWER switch once to activate the Auto-degauss cycle*.

Picture is flickering

- If the refresh rate is not appropriate, the picture may flicker. Set the refresh rate of the non-interlace mode as high as possible on the computer. For details on how to set the refresh rate, consult the dealer of your computer or video board.

Screen image is not centered or sized properly

- Adjust the "CENTER," "SIZE," or "GEOMETRY" on the OSD (pages 5, 6).
- Some video modes do not fill the screen to the edge of the monitor. There is no single answer to solve the problem. There is a tendency to have this problem on higher refresh timings and Macintosh video timings.

Picture is fuzzy

- Adjust the "CONTRAST" and "BRIGHTNESS" on the OSD (page 5). We have come across several brands of SVGA boards that have an excessive video output level which creates a fuzzy picture at max contrast.
- Trip the POWER switch once to activate the Auto-degauss cycle*.

Picture bounces or has wavy oscillations

- Isolate and eliminate any potential sources of electric or magnetic fields. Common causes for this symptom are electric fans, fluorescent lighting, laser printers, and so on.
- If you have another monitor close to this monitor, increase the distance between them to reduce the interference.
- Try plugging the monitor into a different AC outlet, preferably on a different circuit.
- Try the monitor on a completely different computer in a different room.

Picture appears to be ghosting

- Eliminate the use of video cable extension cables and/or video switch boxes if this symptom occurs. Excessive cable length or weak connections can produce this symptom.

A fine horizontal line (wire) is visible

- This wire stabilizes the vertically striped Aperture Grille (page 8). This Aperture Grille allows more light to pass through to the screen giving the Trinitron CRT more color and brightness.

Wavy or elliptical (moire) pattern is visible

- Due to the relationship between resolution, monitor AG pitch and the pitch of some image patterns, certain screen backgrounds, especially gray, sometimes show moire. This can only be eliminated by changing your desktop pattern.

Just after turning the monitor on, a "boon" noise is heard

- Just after turning the monitor on, a noise may be heard for about 3 seconds. This noise is not failure, it is caused by the Auto-degauss cycle*.

* The Auto-degauss function demagnetizes the metal frame of the CRT to obtain a neutral field for uniform color reproduction. If a second degauss cycle is needed, allow a minimum interval of 20 minutes for the best result.

- If the problem persists, call your authorized Sony dealer from a location near your monitor.
- Note the model name and the serial number of your monitor. Also note the make and name of your computer and video board.

SECTION 2 DISASSEMBLY

2-1. CABINET REMOVAL

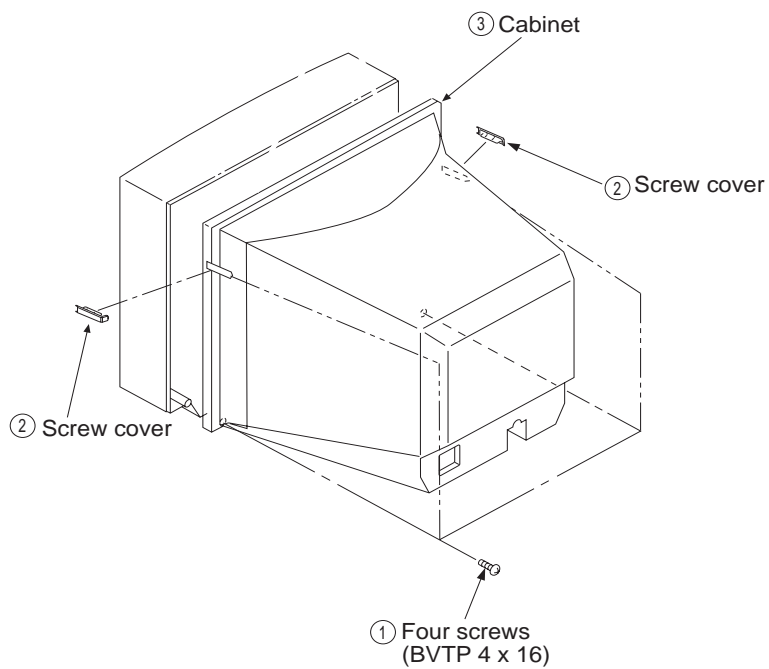

2-2. SERVICE POSITION

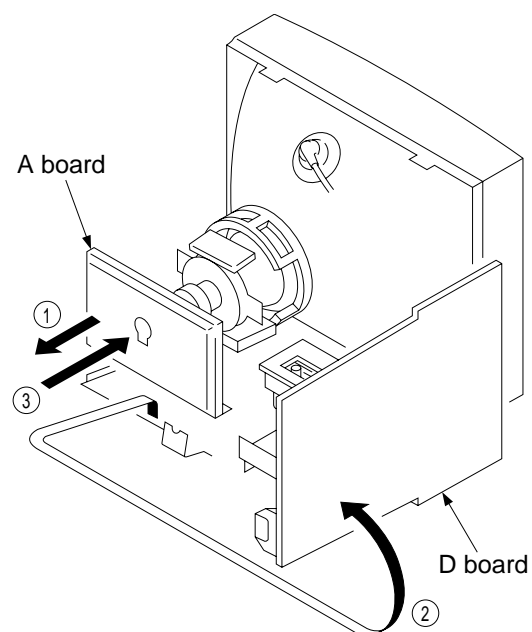

2-3. D BOARD REMOVAL

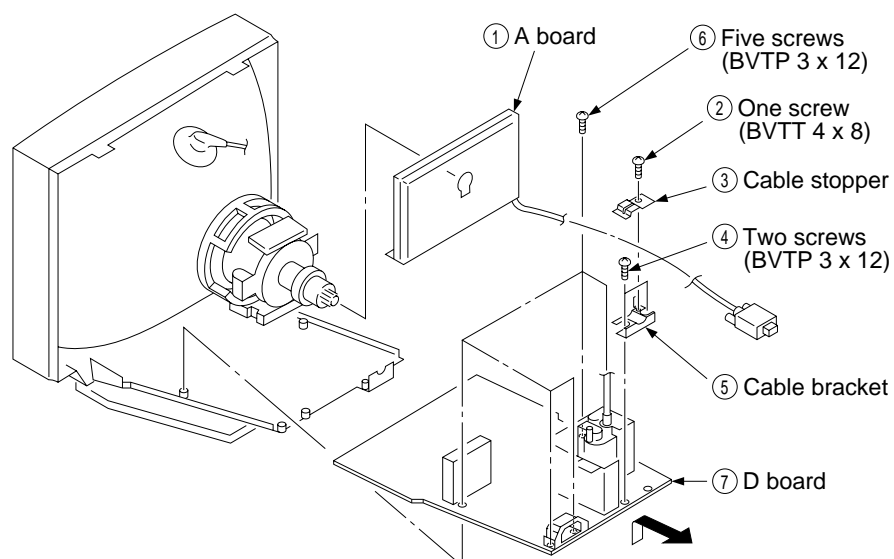

2-4. PICTURE TUBE REMOVAL

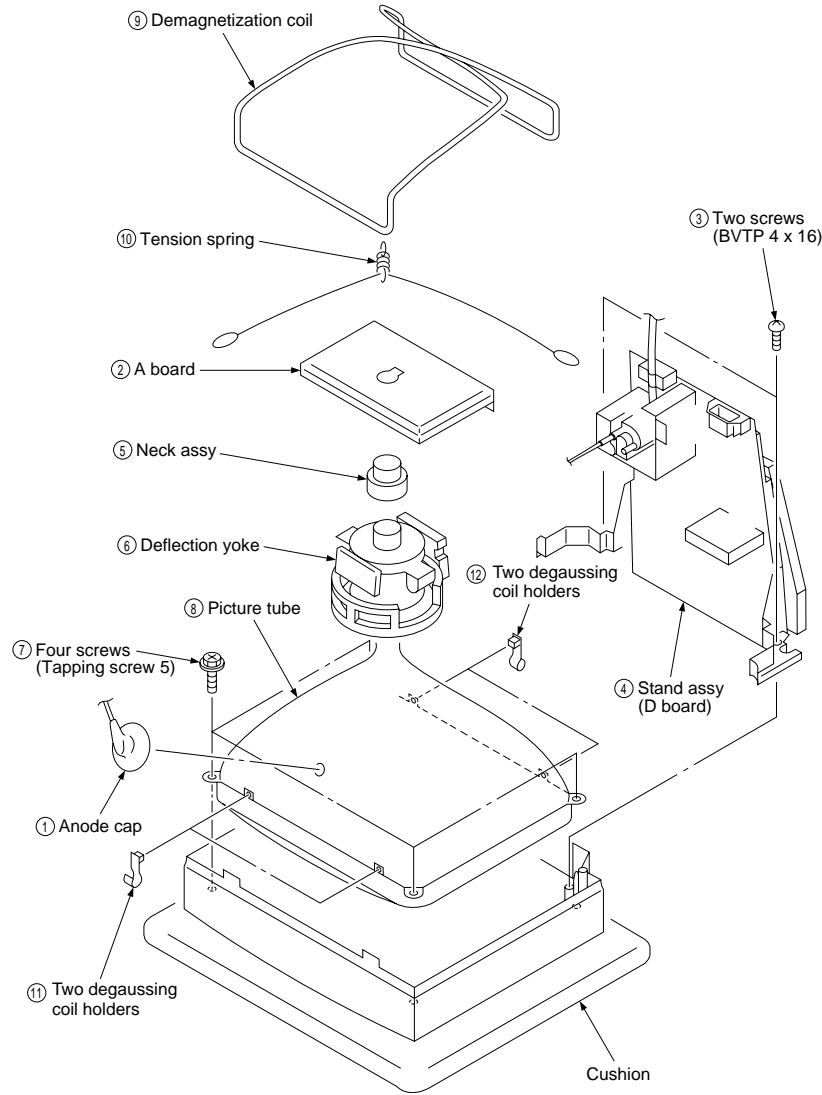

• REMOVAL OF THE ANODE-CAP

NOTE: Short circuit the anode of the picture tube and the anode cap to the metal chassis, CRT shield or carbon painted on the CRT, after removing the anode.

• REMOVAL PROCEDURES

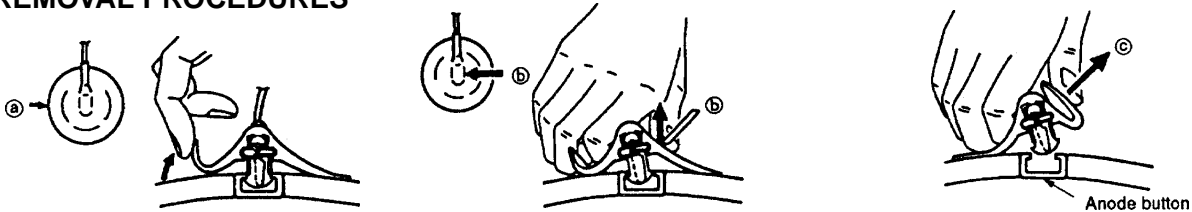

- ① Turn up one side of the rubber cap in the direction indicated by arrow ①.
- ② Use your thumb to pull the rubber cap firmly in the direction indicated by arrow ②.
- ③ When one side of the rubber cap separates from the anode button, the anode-cap can be removed by turning the rubber cap and pulling it in the direction of arrow ③.

• HOW TO HANDLE AN ANODE-CAP

- ① Do not use sharp objects which may cause damage to the surface of the anode-cap.
- ② Do not squeeze the rubber covering too hard to avoid damaging the anode-cap. A material fitting called a shatter-hook terminal is built into the rubber.
- ③ Do not force turn the foot of the rubber cover. This may cause the shatter-hook terminal to protrude and damage the rubber.

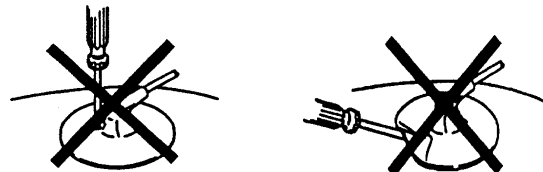

SECTION 3 SAFETY RELATED ADJUSTMENT

- When replacing parts shown in the table below, the following operational checks must be performed as a safety precaution against X-rays emissions from the unit.

D - BOARD
Part Replaced (☒)
RV501
Part Replaced (☑)
IC801, IC901, IC904, FBT (T501) D511, D515, D596, R532, R533, R534, R535, R538, R539, R540, R541, R542, R543, R544, R545, R807, R822, R823, R824, R939, R996, RV501, C509, C515, C516, C517, C519, C528, C542, C548, C549, C802, C814, C815, C904, C910

※ Allow the unit to warm up for one minute prior to checking the following conditions.

a) HV Regulator Check

- 1) Input white cross hatch signal. (fH = 64 kHz)
- 2) Minimum CONT and BRT controls.
- 3) Cut off Screen VR (G2).
- 4) Input voltage: 120 ± 2 VAC
- 5) Confirm that the voltage is within the voltage range shown below.

Standard voltage: $25.0KV \pm 0.5KV$

- 6) When replacing components identified by ☑, make sure to recheck the High Voltage.
- 7) Verify the High Voltage as shown above ($25.0KV \pm 0.5KV$) is within specification. If not, set H. SIZE data at minimum (-127) and then adjust RV501 on "D" Board.
- 8) After adjusting the High Voltage within specification, put the RV cover on RV501 as shown below and apply sufficient amount of RTV around RV501.

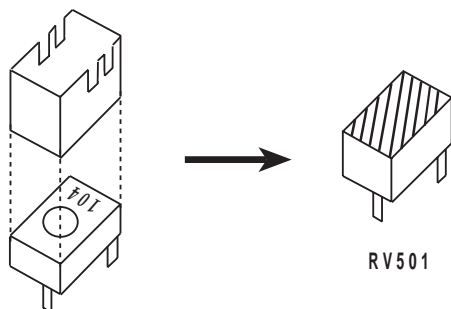

b) HV Hold-Down Check

- 1) Using an external DC Power supply, apply the voltage shown below between cathode of D511 on "D" Board and GND, and confirm that the HV Hold-Down circuit works. (Raster disappears)
Standard voltage: 35.20 ± 0.05 VDC

Check Condition

- Input voltage : 120 ± 2 VAC
- Input signal : Any pattern (fH = 64 kHz)
- Controls : CONT and BRT → Minimum
: Screen VR (G2)2 Cutoff

c) Beam Protector Check (Software logic)

- 1) Using an external DC power supply, apply the voltage $7.00 + 0.05$ VDC between pin ⑪ of FBT (T501) and GND, and confirm that the voltage of both ends C519 is within the voltage range shown below.
Standard voltage: Less than 3.26 VDC

Check Condition

- Input voltage : 120 ± 2 VAC
- Input signal : Any pattern (fH = 64 kHz)
- Controls : CONT and BRT → Minimum
: Screen VR (G2) → Cutoff

d) +B MAX. Check

- 1) Input white cross hatch (fH = 64 kHz) signal.
- 2) Minimum CONT and BRT controls.
- 3) Input voltage: 120 ± 2 VAC
Note: Use NF power supply or make sure that distortion factor is 3% or less.
- 4) Confirm that the voltage is within the voltage range shown below.
Standard voltage: 143 ± 2 VDC

SECTION 4 ADJUSTMENTS

Connect the communication cable of the connector located on the D board on the monitor. Run the service software and then follow the instructions.

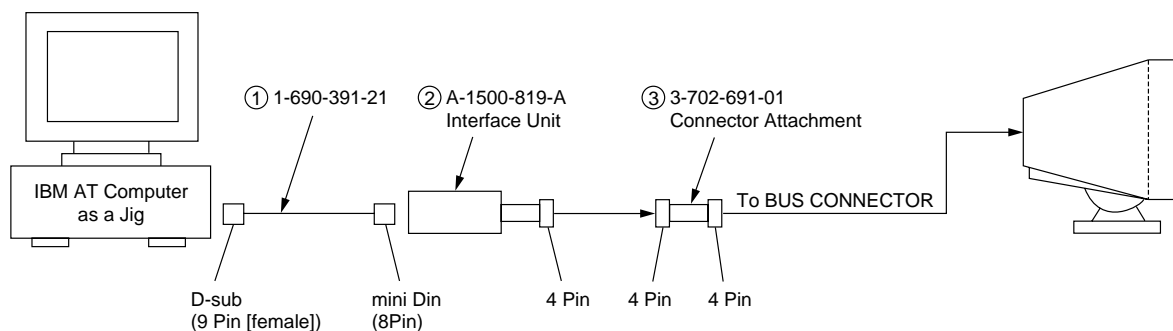

*The parts above (1)~(3) are necessary for DAS adjustment.

※ Allow a 30 minute warm-up period prior to making the following adjustments.

● Landing Rough Adjustment

1. Enter the full white signal.
2. Adjust the contrast to the maximum.
3. Make the screen monogreen.
4. Reverse the DY, and adjust coarsely the purity magnet so that a green raster positions in the center of screen.
5. Moving the DY forward, adjust so that an entire screen becomes monogreen.
6. Adjust the tilt of DY, and fix lightly with a clamp.

● Landing Fine Adjustment

1. Place the set in the Helmholtz coil.
2. Enter a green signal only.
3. Degauss the entire screen with hand-degausser.
4. Attach a wobbling coil to the specified position of CRT neck.
5. Attach a landing adjuster sensor on the CRT.
6. Using a landing checker, adjust the DY position, purity, tilt of DY.
7. Clamp the DY screw.

Clamping torque: 22 ± 2 kgcm (2.2 ± 0.2 N.m)

● Convergence Rough Adjustment

1. Enter the white crosshatch signal.
2. Adjust roughly the horizontal and vertical convergence at four-pole magnet.
3. Adjust roughly HMC and VMC at six-pole magnet.

● Convergence Fine Adjustment

Set DY four-pole magnet to mechanical center before adjustment.

This should be prime mode.

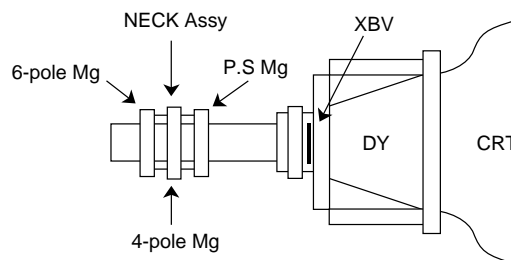
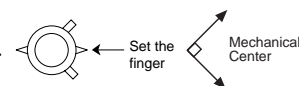

1. Receive R.B. cross-hatch.
2. Adjust H.STAT and V.STAT at four-pole magnet.

< 4 Pole Magnet >

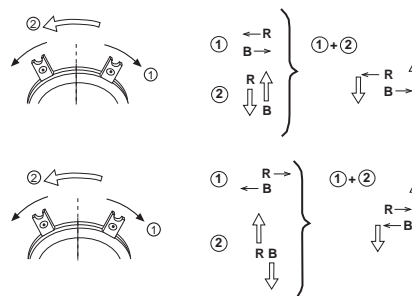

3. Receive White cross-hatch.
4. Adjust HMC and VMC at six-pole magnet.

< 6 Pole Magnet >

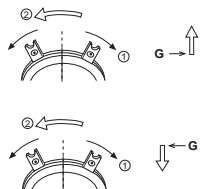

5. Receive R.B. cross-hatch.
6. Adjust XBV at DY four-pole magnet.

XBV Correction

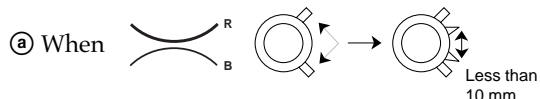

- 1) Open DY four-pole. (Do not move H.STAT)
- 2) Re-adjust V.STAT with four-pole at NECK Ass'y.

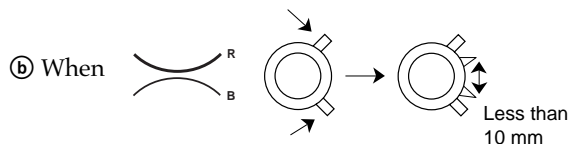

- 1) Close DY four-pole. (Do not move H.STAT)
- 2) Re-adjust V.STAT with four-pole at NECK Ass'y.

7. Repeat the above procedure so that R.G.B. will on X, Y axis.
8. Adjust H.TILT by swinging the DY neck right and left.
9. Adjust XCV with XCV core.

XCV movement



10. Adjust V.TILT with TLV VR.

TLV movement

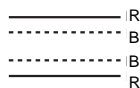

11. Adjust Y.CROSS with YCH VR.

YCH movement

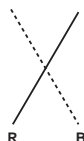

12. Paint lock the four-pole and six-pole Mg.

<VR Adjustment on DY>

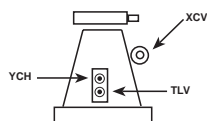

<Zero Position NECK Ass'y>

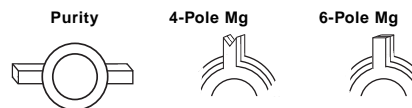

DY XB

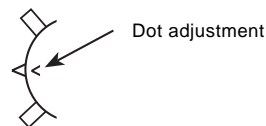

● Vertical and Horizontal Position and Size Specification

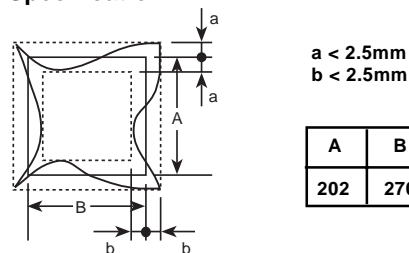

● Convergence Specification

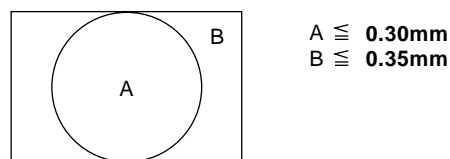

● Focus adjustment

Adjust focus (V) and focus (H) for optimum focus.

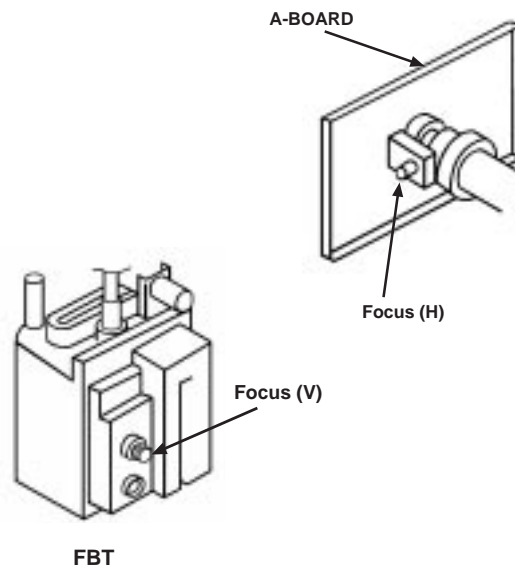

5-2. CIRCUIT BOARDS LOCATION

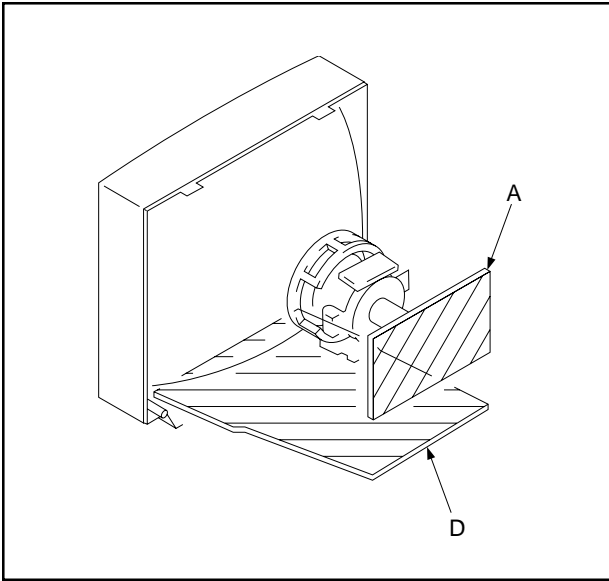

5-3. SCHEMATIC DIAGRAMS AND PRINTED WIRING BOARDS

Note:

- All capacitors are in μF unless otherwise noted. pF: μF 50 WV or less are not indicated except for electrolytic.
- Indication of resistance, which does not have one for rating electrical power, is as follows.

Pitch: 5 mm
Rating electrical power 1/4 W (CHIP: 1/10 W)

- All resistors are in ohms.
- : nonflammable resistor.
- : fusible resistor.
- Δ : internal component.
- : panel designation and adjustment for repair.
- All variable and adjustable resistors have characteristic curve B, unless otherwise noted.
- \perp : earth-ground.
- : earth-chassis.
- The components identified by in this basic schematic diagram have been carefully factory-selected for each set in order to satisfy regulations regarding X-ray radiation. Should replacement be required, replace only with the value originally used.
- When replacing components identified by , make the necessary adjustments by using RV501 () as indicated. (See page 9)

Note: The components identified by shading and mark Δ are critical for safety. Replace only with part number specified.

Les composants identifiés par un trame et une marque Δ sont critiques pour la sécurité. Ne les remplacer que par une pièce portant le numéro spécifié.

- When replacing parts shown in the table below, be sure to perform the safety related adjustment.

D - BOARD
Part Replaced ()
RV501
Part Replaced ()
IC801, IC901, IC904, FBT (T501) D511, D515, D596, R532, R533, R534, R535, R538, R539, R540, R541, R542, R543, R544, R545, R807, R822, R823, R824, R939, R996, RV501, C509, C515, C516, C517, C519, C528, C542, C548, C549, C802, C814, C815, C904, C910

- All voltages are in Volts.
- Readings are taken with a 10 M Ω digital multimeter.
- Readings are taken with a color-bar signal input.
- Voltage variations may be noted due to normal production tolerances.
- * : Cannot be measured.
- Circled numbers are waveform references.
- : B +bus.
- : B - bus.

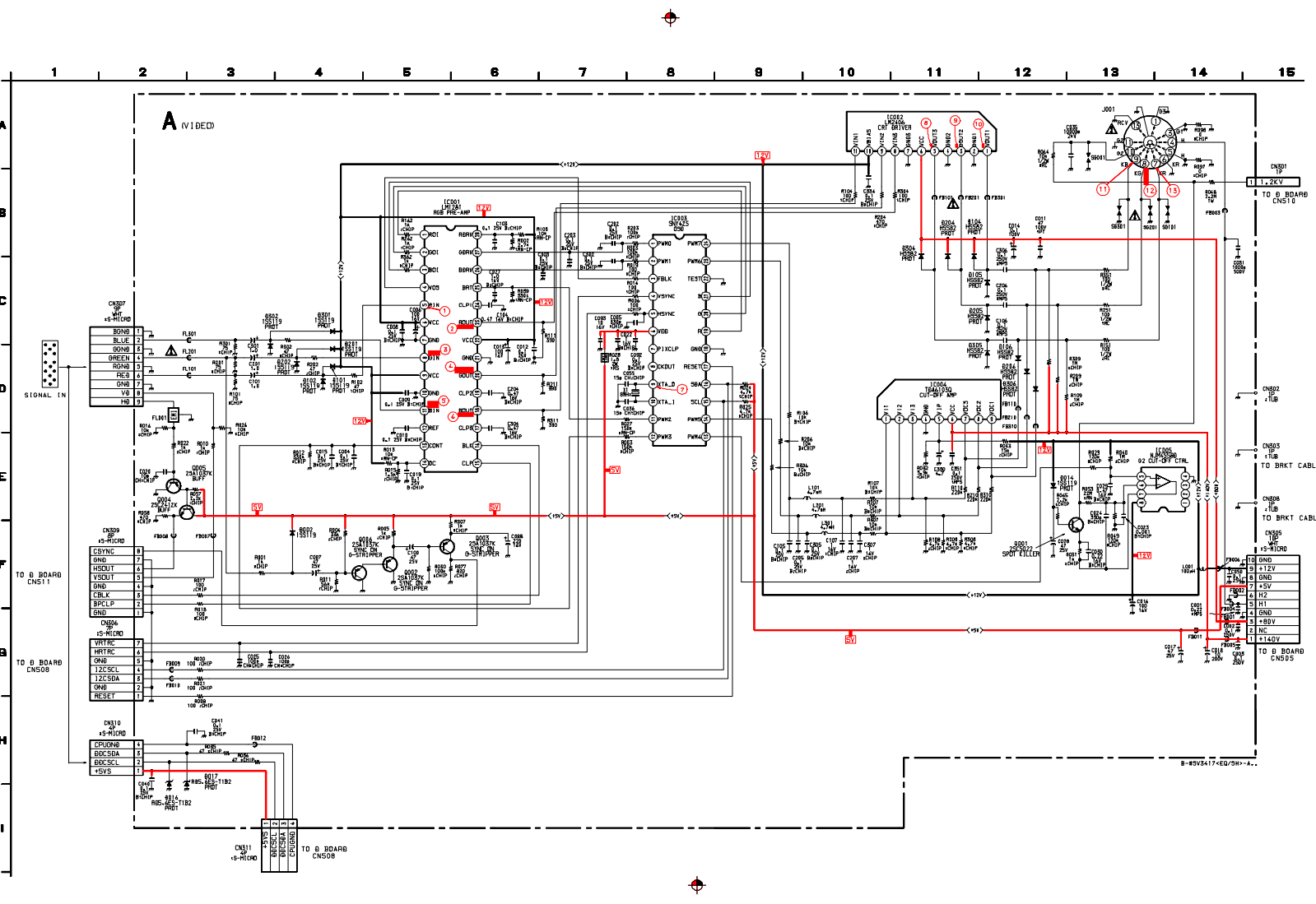

5-4. SEMICONDUCTORS

MTZJ-T77-4.7B
 MTZJ-T77-5.8B
 MTZJ-T77-6.2B
 RB441QT-77
 RD27ES-T1B2
 MTZJ-T77-10B
 MTZJ-T77-18
 RD4.7ES-T1B2
 RD5.6ES-T1B2
 1SS119-2STD



EGP20DPKG23
 EGP10GPKG23
 1SS133T-77

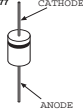

UF3ML-6505
 RGP02-20EL-6394
 30L41A (LCP-15)
 HSS 82

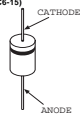

2SC5022-02

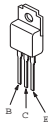

EGP30D
 2SA1037K-T-146-QR

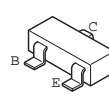

TDA103Q



SB340L-6489

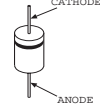

STU252

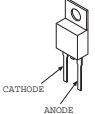

LM1281

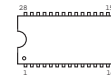

SN74HCT02AN



SNY425

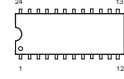

TDA8105S

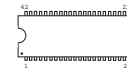

VPC5023CS-095

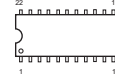

ST7272NSB1CKO

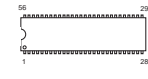

MC 44603P

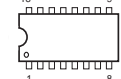

TL 431CLP



NJM4558D



GP104005-E-G23



GBU4JL-6088



TDA 8172



UF4007G23



2SD2394-F



LA 6500-FA



SEL1422G-C
 SG232D-658
 SEL1922D-C
 SY432W-M-658



2SC3941A-Q (TA)



2SA1048TP-VGR
 2SC3311A-QRSTA
 2SA1309A-QRSTA



2SC3209-TK



2SC2001TP-K2



2SB1373
 2SB1565F



2SC5129



LM2406T



PST6000-T



IRFBC40G-LF38



2SD1640Q



MOC8105TV



IRF19630



DTC124ES-TP



2SK1904



2SK2562-01-F165



SECTION 6 EXPLODED VIEWS

- Items with no part number and no description are not stocked because they are seldom required for routine service.
- The component parts of an assembly are indicated by the reference numbers in the remarks column.

- Items marked " * " are not stocked since they are seldom required for routine service. Some delay should be anticipated when ordering these items.

The components identified by shading and mark **Δ** are critical for safety. Replace only with part number specified.

Les composants identifiés par un trame et une marque **Δ** sont critiques pour la sécurité. Ne les remplacer que par une pièce portant le numéro spécifié.

6-1. CHASSIS

- 7-685-648-79 SCREW +BVTP 3X12
- △ 7-685-663-71 SCREW +BVTP 4X16

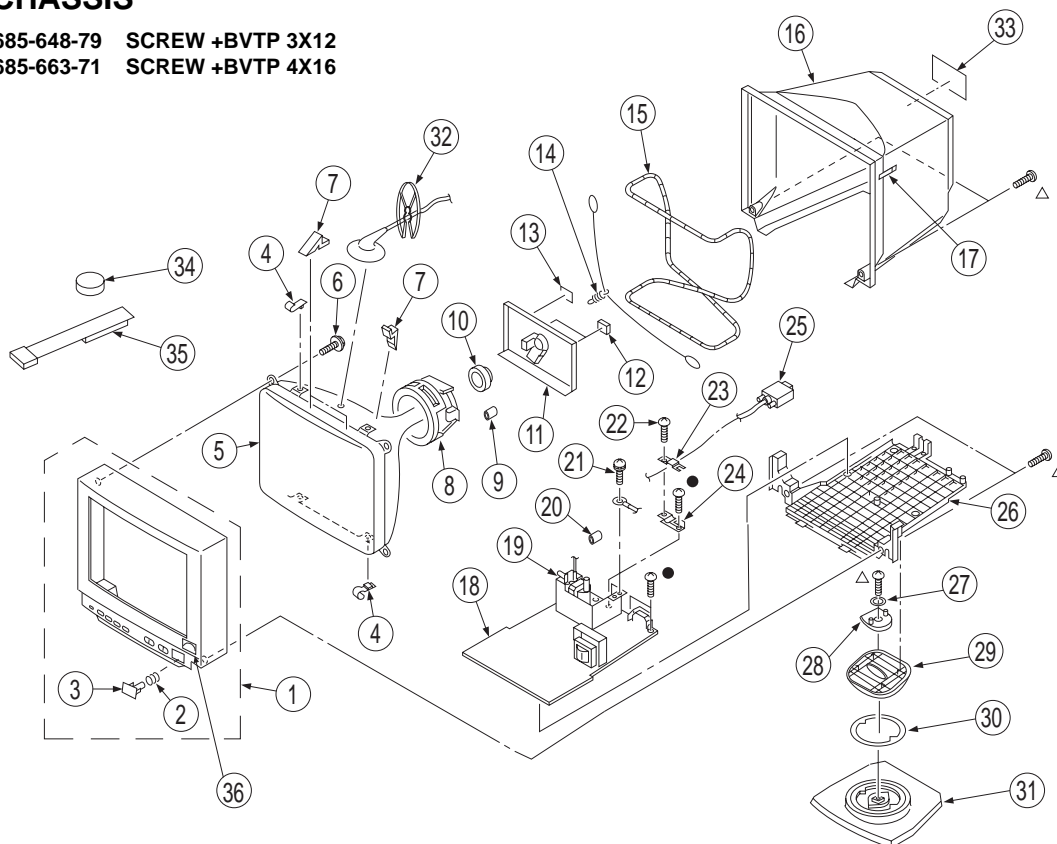

REF.NO.	PART NO.	DESCRIPTION	REMARK	REF.NO.	PART NO.	DESCRIPTION	REMARK
1	*	X-4034-789-1 BEZEL ASSY	2-3	19	Δ	X-4033-083-1 TRANSFORMER ASSY, FLYBACK (NX-4130//J1E)	
2		4-060-162-01 SPRING, COMPRESSION		20		1-543-653-11 CORE ASSY, BEAD (DIVISION TYPE)	
3		4-060-157-01 BUTTON, POWER		21		4-389-025-01 SCREW (M4x8)(EXT.TOOTHWASHER)	
4		4-045-123-01 HOLDER, DEGAUSSING COIL		22		7-685-659-71 SCREW + BVTT 4x8 (S)	
5	Δ	8-734-827-05 CRT 15FR2 (M36LDJ15X) (EQ)		23	*	4-060-151-01 STOPPER, CABLE	
5	Δ	8-734-829-05 CRT 15FR2 (M36LDJ15X) (SH)		24	*	4-060-150-01 BRACKET, CABLE	
6		4-365-808-01 SCREW (5), TAPPING		25		1-776-975-11 CABLE ASSY (15P D-SUB)	
7		4-060-166-01 SPACER, DY		26	*	4-060-177-01 COVER, BOTTOM	
8	Δ	8-451-469-21 DY Y15FRF2M2		27	*	4-060-178-01 HOLDER, STAND	
9		1-500-386-11 FILTER CLAMP (FERRITE CORE)		28		4-060-183-01 STOPPER (A), STAND	
10	Δ	1-452-756-11 NECK ASSY (NA293)		29	*	4-060-179-01 SLIDER	
11	*	A-1298-209-A A BOARD, COMPLETE		30	*	4-060-180-01 RING, TILT SWIVEL	
12	*	4-060-175-01 CUSHION (A)		31	*	X-4034-791-1 STAND BASE, ASSY	
13	*	4-060-153-01 LABEL, X-RAY		32		4-060-155-01 HOLDER, HV CABLE	
14		4-060-184-01 SPRING, TENSION		33	*	4-060-154-01 LABEL, INFORMATION	
15	Δ	1-409-799-11 COIL, DEMAGNETIZATION		34		1-452-032-00 MAGNET, DISC	
16		4-060-149-01 CABINET		35	*	X-4034-792-1 PERMALLOY ASSY, STAND	
17		4-060-165-01 COVER, SCREW		36	*	4-060-152-01 LABEL, ENERGY STAR	
18	*	A-1346-652-A D BOARD, COMPLETE					

6-2. PACKING MATERIALS

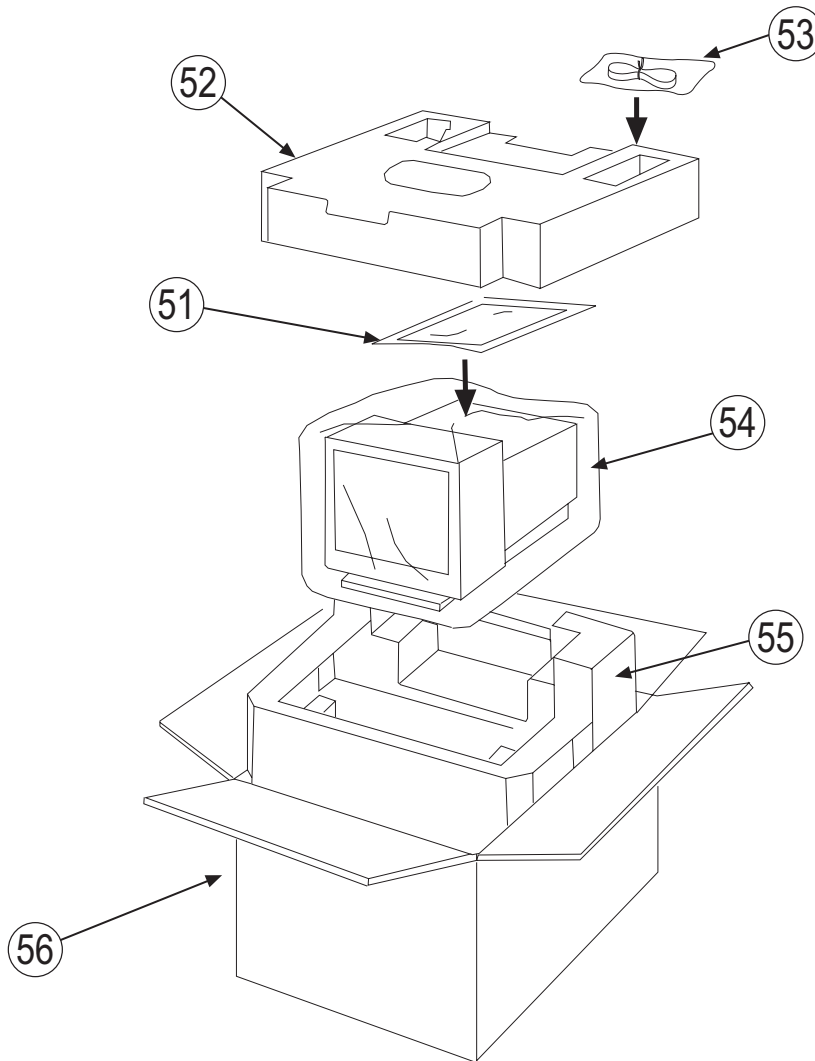

REF.NO.	PART NO.	DESCRIPTION	REMARK
51	3-860-654-01	MANUAL, INSTRUCTION	
52	* 4-060-187-01	CUSHION (TOP) ASSY.	
53	△ 1-765-717-11	CORD SET, POWER	(EQ)
53	△ 1-558-481-11	CORD SET, POWER	(SH)
54	* 4-060-194-01	BAG, POLYETHYLENE	
55	* 4-060-192-01	CUSHION (BOTTOM) ASSY.	
56	* 4-060-871-01	INDIVIDUAL CARTON	



Note: The components identified by shading and mark Δ are critical for safety. Replace only with part number specified.

Note: Les composants identifiés par un trame et une marque Δ sont critiques pour la sécurité. Ne les remplacer que par une pièce portant le numéro spécifié.

REF.NO.	PART NO.	DESCRIPTION	REMARK
CN303	1-695-915-11	TAB (CONTACT)	
CN305	1-564-513-11	PLUG, CONNECTOR 10P	
CN306 *	1-564-510-11	PLUG, CONNECTOR 7P	
CN307 *	1-564-512-11	PLUG, CONNECTOR 9P	
CN308	1-695-915-11	TAB (CONTACT)	
CN309	1-564-511-11	PLUG, CONNECTOR 8P	
CN310 *	1-564-507-11	PLUG, CONNECTOR 4P	
CN311 *	1-564-507-11	PLUG, CONNECTOR 4P	

DIODE

D002	8-719-911-19	DIODE 1SS119-25	
D014	8-719-911-19	DIODE 1SS119-25	
D016	8-719-109-89	DIODE RD5.6ESB2	
D017	8-719-109-89	DIODE RD5.6ESB2	
D101	8-719-911-19	DIODE 1SS119-25	
D102	8-719-911-19	DIODE 1SS119-25	
D104	8-719-970-83	DIODE HSS82	
D105	8-719-970-83	DIODE HSS82	
D106	8-719-970-83	DIODE HSS82	
D201	8-719-911-19	DIODE 1SS119-25	
D202	8-719-911-19	DIODE 1SS119-25	
D204	8-719-970-83	DIODE HSS82	
D205	8-719-970-83	DIODE HSS82	
D206	8-719-970-83	DIODE HSS82	
D301	8-719-911-19	DIODE 1SS119-25	
D302	8-719-911-19	DIODE 1SS119-25	
D304	8-719-970-83	DIODE HSS82	
D305	8-719-970-83	DIODE HSS82	
D306	8-719-970-83	DIODE HSS82	

FERRITE BEAD

FB001	1-412-911-11	INDUCTOR	
FB002	1-412-911-11	INDUCTOR	
FB003	1-412-911-11	INDUCTOR	
FB004	1-412-911-11	INDUCTOR	
FB005	1-412-911-11	INDUCTOR	
FB006	1-412-911-11	INDUCTOR	
FB007	1-412-911-11	INDUCTOR	
FB008	1-412-911-11	INDUCTOR	
FB009	1-412-911-11	INDUCTOR	
FB010	1-412-911-11	INDUCTOR	
FB011	1-412-911-11	INDUCTOR	
FB012	1-412-911-11	INDUCTOR	
FB101 Δ	1-500-104-21	INDUCTOR	
FB110	1-412-911-11	INDUCTOR	
FB201 Δ	1-500-104-21	INDUCTOR	
FB210	1-412-911-11	INDUCTOR	
FB301 Δ	1-500-104-21	INDUCTOR	
FB310	1-412-911-11	INDUCTOR	

REF.NO.	PART NO.	DESCRIPTION	REMARK
FILTER			
FL001	1-421-995-11	FILTER, NOISE	
FL101 Δ	1-414-793-21	INDUCTOR	
FL201 Δ	1-414-793-21	INDUCTOR	
FL301 Δ	1-414-793-21	INDUCTOR	

IC

IC001	8-759-366-36	IC LM1281	
IC002	8-759-399-84	IC LM2406T	
IC003	8-759-399-76	IC SNY425	
IC004	8-759-434-40	IC TDA6103Q/N3,112	
IC005	8-759-634-51	IC M5218AP	

JACK

J001 Δ	1-251-335-11	SOCKET, CRT	
---------------	--------------	-------------	--

COIL

L001	1-412-537-31	INDUCTOR	10
L101	1-407-500-00	INDUCTOR	4.7MMH
L201	1-407-500-00	INDUCTOR	4.7MMH
L301	1-407-500-00	INDUCTOR	4.7MMH

TRANSISTOR

Q001	8-729-032-61	TRANSISTOR 2SC5022-02	
Q002	8-729-216-22	TRANSISTOR 2SA1162-G	
Q003	8-729-216-22	TRANSISTOR 2SA1162-G	
Q004	8-729-120-28	TRANSISTOR 2SC1623-L5L6	
Q005	8-729-216-22	TRANSISTOR 2SA1162-G	
Q006	8-729-216-22	TRANSISTOR 2SA1162-G	

RESISTOR

R001	1-216-049-91	METAL GLAZE	1K	5%	1/10W
R002	1-216-661-11	METAL CHIP	2.7K	0.50%	1/10W
R003	1-216-101-00	METAL GLAZE	150K	5%	1/10W
R004	1-216-085-00	METAL GLAZE	33K	5%	1/10W
R005	1-216-049-91	METAL GLAZE	1K	5%	1/10W
R006	1-216-025-91	METAL GLAZE	100	5%	1/10W
R007	1-216-049-91	METAL GLAZE	1K	5%	1/10W
R008	1-216-025-91	METAL GLAZE	100	5%	1/10W
R010	1-216-049-91	METAL GLAZE	1K	5%	1/10W
R011	1-216-091-00	METAL GLAZE	56K	5%	1/10W
R012	1-216-109-00	METAL GLAZE	330K	5%	1/10W
R013	1-216-675-11	METAL CHIP	10K	0.50%	1/10W
R014	1-216-025-91	METAL GLAZE	100	5%	1/10W
R015	1-216-053-00	METAL GLAZE	1.5K	5%	1/10W
R016	1-216-073-00	METAL GLAZE	10K	5%	1/10W
R017	1-216-025-91	METAL GLAZE	100	5%	1/10W
R018	1-216-025-91	METAL GLAZE	100	5%	1/10W

Note: The components identified by shading and mark **Δ** are critical for safety. Replace only with part number specified.

Note: Les composants identifiés par un trame et une marque **Δ** sont critiques pour la sécurité. Ne les remplacer que par une pièce portant le numéro spécifié.



REF.NO.	PART NO.	DESCRIPTION	REMARK
R019	1-216-025-91	METAL GLAZE	100 5% 1/10W
R020	1-216-025-91	METAL GLAZE	100 5% 1/10W
R021	1-216-025-91	METAL GLAZE	100 5% 1/10W
R022	1-216-049-91	METAL GLAZE	1K 5% 1/10W
R024	1-216-065-00	METAL GLAZE	4.7K 5% 1/10W
R025	1-216-065-00	METAL GLAZE	4.7K 5% 1/10W
R026	1-216-073-00	METAL GLAZE	10K 5% 1/10W
R027	1-218-756-11	METAL CHIP	150K 0.50% 1/10W
R028	1-216-372-11	METAL OXIDE	1.8 5% 2W F
R029	1-216-099-00	METAL GLAZE	120K 5% 1/10W
R030	1-216-097-91	METAL GLAZE	100K 5% 1/10W
R031	1-216-049-91	METAL GLAZE	1K 5% 1/10W
R032	1-216-665-11	METAL CHIP	3.9K 0.50% 1/10W
R033	1-216-679-11	METAL CHIP	15K 0.50% 1/10W
R035	1-216-017-91	METAL GLAZE	47 5% 1/10W
R036	1-216-017-91	METAL GLAZE	47 5% 1/10W
R039	1-218-764-11	METAL CHIP	330K 0.50% 1/10W
R040	1-216-121-91	METAL GLAZE	1M 5% 1/10W
R045	1-216-057-00	METAL GLAZE	2.2K 5% 1/10W
R048	1-211-885-21	METAL	2.2M 5% 1W
R049	1-216-099-00	METAL GLAZE	120K 5% 1/10W
R053	1-219-621-91	METAL	22M 10% 1/4W
R057	1-216-057-00	METAL GLAZE	2.2K 5% 1/10W
R058	1-216-041-00	METAL GLAZE	470 5% 1/10W
R064	1-202-830-00	SOLID	10K 20% 1/2W
R077	1-216-047-91	METAL GLAZE	820 5% 1/10W
R097	1-216-295-91	SHORT	0
R098	1-216-295-91	SHORT	0
R101	1-216-624-11	METAL CHIP	75 0.50% 1/10W
R102	1-216-017-91	METAL GLAZE	47 5% 1/10W
R103	1-216-675-11	METAL CHIP	10K 0.50% 1/10W
R104	1-216-025-91	METAL GLAZE	100 5% 1/10W
R106	1-216-073-00	METAL GLAZE	10K 5% 1/10W
R107	1-216-073-00	METAL GLAZE	10K 5% 1/10W
R108	1-216-667-11	METAL CHIP	4.7K 0.50% 1/10W
R109	1-216-121-91	METAL GLAZE	1M 5% 1/10W
R110	1-215-477-00	METAL	220K 1% 1/4W
R111	1-249-412-11	CARBON	390 5% 1/4W
R151	1-202-549-00	SOLID	100 20% 1/2W
R162	1-216-049-91	METAL GLAZE	1K 5% 1/10W
R201	1-216-624-11	METAL CHIP	75 0.50% 1/10W
R202	1-216-017-91	METAL GLAZE	47 5% 1/10W
R203	1-216-097-91	METAL GLAZE	100K 5% 1/10W
R204	1-216-041-00	METAL GLAZE	470 5% 1/10W
R206	1-216-073-00	METAL GLAZE	10K 5% 1/10W
R207	1-216-073-00	METAL GLAZE	10K 5% 1/10W
R208	1-216-667-11	METAL CHIP	4.7K 0.50% 1/10W
R209	1-216-121-91	METAL GLAZE	1M 5% 1/10W
R210	1-215-477-00	METAL	220K 1% 1/4W

REF.NO.	PART NO.	DESCRIPTION	REMARK
R211	1-249-412-11	CARBON	390 5% 1/4W
R251	1-202-549-00	SOLID	100 20% 1/2W
R262	1-216-049-91	METAL GLAZE	1K 5% 1/10W
R301	1-216-624-11	METAL CHIP	75 0.50% 1/10W
R302	1-216-017-91	METAL GLAZE	47 5% 1/10W
R303	1-216-097-91	METAL GLAZE	100K 5% 1/10W
R304	1-216-025-91	METAL GLAZE	100 5% 1/10W
R306	1-216-073-00	METAL GLAZE	10K 5% 1/10W
R307	1-216-073-00	METAL GLAZE	10K 5% 1/10W
R308	1-216-667-11	METAL CHIP	4.7K 0.50% 1/10W
R309	1-216-121-91	METAL GLAZE	1M 5% 1/10W
R310	1-215-477-00	METAL	220K 1% 1/4W
R311	1-249-412-11	CARBON	390 5% 1/4W
R351	1-202-549-00	SOLID	100 20% 1/2W
R362	1-216-049-91	METAL GLAZE	1K 5% 1/10W

SPARK GAP

SG001 Δ	1-519-422-11	GAP, SPARK
SG101 Δ	1-519-504-11	GAP, DISCHARGE
SG201 Δ	1-519-504-11	GAP, DISCHARGE
SG301 Δ	1-519-504-11	GAP, DISCHARGE

CRYSTAL

X1 1-567-890-11 VIBRATOR, CRYSTAL



* A-1346-652-A D BOARD, COMPLETE

1-533-223-11 HOLDER, FUSE
 1-900-214-27 LEAD ASSY, FOCUS
 * 1-900-801-67 CONNECTOR ASSY
 4-045-132-01 HOLDER (A), LED

4-382-854-11 SCREW (M3X10), P, SW (+)
 4-389-025-01 SCREW (M4) (EXT TOOTH WASHER)

CAPACITOR

C401	1-128-528-11	ELECT	470MF	20%	25V
C402	1-106-228-00	MYLAR	0.22MF	10%	100V
C403	1-137-399-11	FILM	0.1MF	5%	50V
C404	1-107-894-11	ELECT	220MF	20%	35V
C405	1-101-006-00	CERAMIC	0.047MF		50V
C406	1-137-375-11	FILM	0.068MF	5%	50V
C410	1-107-914-11	ELECT	1000MF	20%	25V
C420	1-137-368-11	FILM	0.0047MF	5%	50V
C500	1-136-169-00	FILM	0.22MF	5%	50V



Note: The components identified by shading and mark Δ are critical for safety. Replace only with part number specified.

Note: Les composants identifiés par un trame et une marque Δ sont critiques pour la sécurité. Ne les remplacer que par une pièce portant le numéro spécifié.

REF.NO.	PART NO.	DESCRIPTION	REMARK
C502	1-137-370-11	FILM	0.01MF 5% 50V
C503	1-107-667-11	ELECT	2.2MF 20% 160V
C505	1-126-964-11	ELECT	10MF 20% 50V
C506	1-137-370-11	FILM	0.01MF 5% 50V
C507	1-162-318-11	CERAMIC	0.001MF 10% 500V
C508	1-109-878-11	CERAMIC	15PF 5% 2KV
C509	1-136-169-00	FILM	0.22MF 5% 50V
C511	1-101-810-00	CERAMIC	100PF 5% 500V
C512	1-137-399-11	FILM	0.1MF 5% 50V
C513	1-106-383-00	MYLAR	0.047MF 10% 200V
C514	1-126-941-11	ELECT	470MF 20% 25V
C515	1-136-203-11	FILM	10000PF 5% 630V
C516	1-126-960-11	ELECT	1MF 20% 50V
C517	1-137-370-11	FILM	0.01MF 5% 50V
C518	1-102-002-00	CERAMIC	680PF 10% 500V
C519	1-126-963-11	ELECT	4.7MF 20% 50V
C520	1-107-955-11	ELECT	100MF 20% 200V
C521	1-126-960-11	ELECT	1MF 20% 50V
C523	1-106-375-12	MYLAR	0.022MF 10% 100V
C527	1-162-117-00	CERAMIC	100PF 10% 500V
C528	1-126-965-11	ELECT	22MF 20% 50V
C532	1-106-367-00	MYLAR	0.01MF 10% 200V
C533	1-164-735-11	CAPACITOR	0.0015MF 10% 500V
C534	1-115-349-51	CERAMIC	0.01MF 2KV
C535	1-161-754-00	CERAMIC	0.001MF 10% 2KV
C540 Δ	1-136-064-00	FILM	2200PF 3% 2KV
C541 Δ	1-113-576-11	FILM	0.0043MF 3% 2.5KV
C542	1-137-368-11	FILM	0.0047MF 5% 50V
C544	1-115-349-51	CERAMIC	0.01MF 2KV
C547	1-126-941-11	ELECT	470MF 20% 25V
C548	1-137-425-11	FILM	0.33MF 10% 100V
C549	1-137-399-11	FILM	0.1MF 5% 50V
C550	1-117-206-21	FILM	0.36MF 5% 250V
C562	1-115-511-11	FILM	0.12MF 5% 250V
C565	1-136-169-00	FILM	0.22MF 5% 50V
C566	1-137-370-11	FILM	0.01MF 5% 50V
C567	1-137-370-11	FILM	0.01MF 5% 50V
C568	1-137-370-11	FILM	0.01MF 5% 50V
C569	1-137-370-11	FILM	0.01MF 5% 50V
C570	1-115-519-11	FILM	0.56MF 5% 250V
C576	1-115-516-11	FILM	0.33MF 5% 250V
C582	1-161-754-00	CERAMIC	0.001MF 10% 2KV
C583	1-106-375-12	MYLAR	0.022MF 10% 100V
C593	1-117-206-21	FILM	0.36MF 5% 250V
C598	1-137-399-11	FILM	0.1MF 5% 50V
C599	1-128-582-11	ELECT	10MF 20% 100V
C601	1-104-708-11	FILM	0.47MF 20% 250V
C602 Δ	1-107-533-11	FILM	1MF 20% 250V
C603 Δ	1-113-912-11	CERAMIC	0.0047MF 20% 250V

REF.NO.	PART NO.	DESCRIPTION	REMARK
C604 Δ	1-113-912-11	CERAMIC	0.0047MF 20% 250V
C605 Δ	1-113-896-11	CERAMIC	220PF 10% 250V
C606 Δ	1-113-896-11	CERAMIC	220PF 10% 250V
C607	1-137-368-11	FILM	0.0047MF 5% 50V
C608	1-107-894-11	ELECT	220MF 20% 35V
C609	1-137-399-11	FILM	0.1MF 5% 50V
C610	1-102-115-00	CERAMIC	560PF 10% 50V
C611	1-136-177-00	FILM	1MF 5% 50V
C612	1-137-370-11	FILM	0.01MF 5% 50V
C614	1-102-973-00	CERAMIC	100PF 5% 50V
C615	1-137-364-11	FILM	0.001MF 5% 50V
C616	1-113-912-11	CERAMIC	0.0047MF 20% 250V
C617	1-106-343-00	MYLAR	0.001MF 10% 100V
C618	1-107-884-11	ELECT	1000MF 20% 16V
C619	1-137-366-11	FILM	0.0022MF 5% 50V
C620 Δ	1-109-984-11	ELECT	390MF 20% 400V
C621	1-136-203-11	FILM	10000PF 5% 630V
C622 Δ	1-113-912-11	CERAMIC	0.0047MF 20% 250V
C628	1-137-399-11	FILM	0.1MF 5% 50V
C634	1-126-941-11	ELECT	470MF 20% 25V
C635	1-126-935-11	ELECT	470MF 20% 16V
C650	1-125-700-11	ELECT	220MF 20% 200V
C651	1-107-933-11	ELECT	100MF 20% 100V
C652	1-107-914-11	ELECT	1000MF 20% 25V
C653	1-126-941-11	ELECT	470MF 20% 25V
C662	1-126-941-11	ELECT	470MF 20% 25V
C675	1-137-364-11	FILM	0.001MF 5% 50V
C678	1-162-115-00	CERAMIC	330PF 10% 2KV
C802	1-102-116-00	CERAMIC	680PF 10% 50V
C803	1-102-106-00	CERAMIC	100PF 10% 50V
C804	1-137-364-11	FILM	0.001MF 5% 50V
C805	1-126-965-11	ELECT	22MF 20% 50V
C806	1-126-767-11	ELECT	1000MF 20% 16V
C807	1-137-399-11	FILM	0.1MF 5% 50V
C808	1-137-364-11	FILM	0.001MF 5% 50V
C810	1-124-768-11	ELECT	4.7MF 20% 35V
C811	1-137-399-11	FILM	0.1MF 5% 50V
C812	1-137-365-11	FILM	0.0015MF 5% 50V
C813	1-137-370-11	FILM	0.01MF 5% 50V
C814	1-136-169-00	FILM	0.22MF 5% 50V
C815	1-137-367-11	FILM	0.0033MF 5% 50V
C817	1-126-933-11	ELECT	100MF 20% 16V
C818	1-137-399-11	FILM	0.1MF 5% 50V
C819	1-136-173-00	FILM	0.47MF 5% 50V
C820	1-137-366-11	FILM	0.0022MF 5% 50V
C821	1-102-112-00	CERAMIC	330PF 10% 50V
C822	1-137-368-11	FILM	0.0047MF 5% 50V
C901	1-137-399-11	FILM	0.1MF 5% 50V
C902	1-137-368-11	FILM	0.0047MF 5% 50V



Note: The components Identified by shading and mark Δ are critical for safety. Replace only with part number specified.

Note: Les composants identifiés per un trame et une marque Δ sont critiques pour la securite. Ne les remplacer que par une piece portant le numero specifie.

REF.NO.	PART NO.	DESCRIPTION	REMARK
C903	1-102-951-00	CERAMIC	15PF 5% 50V
C904	1-137-399-11	FILM	0.1MF 5% 50V
C905	1-137-399-11	FILM	0.1MF 5% 50V
C906	1-136-173-00	FILM	0.47MF 5% 50V
C907	1-126-963-11	ELECT	4.7MF 20% 50V
C908	1-102-951-00	CERAMIC	15PF 5% 50V
C910	1-104-664-11	ELECT	47MF 20% 25V
C911	1-126-768-11	ELECT	2200MF 20% 16V
C912	1-126-961-11	ELECT	2.2MF 20% 50V
C913	1-126-961-11	ELECT	2.2MF 20% 50V
C915	1-124-768-11	ELECT	4.7MF 20% 35V
C916	1-126-961-11	ELECT	2.2MF 20% 50V
C917	1-126-961-11	ELECT	2.2MF 20% 50V
C918	1-126-961-11	ELECT	2.2MF 20% 50V
C919	1-126-961-11	ELECT	2.2MF 20% 50V
C920	1-126-961-11	ELECT	2.2MF 20% 50V
C921	1-126-961-11	ELECT	2.2MF 20% 50V
C923	1-137-370-11	FILM	0.01MF 5% 50V
C924	1-137-399-11	FILM	0.1MF 5% 50V
C925	1-126-934-11	ELECT	220MF 20% 16V
C926	1-137-364-11	FILM	0.001MF 5% 50V
C927	1-104-664-11	ELECT	47MF 20% 25V
C928	1-137-370-11	FILM	0.01MF 5% 50V
C929	1-137-399-11	FILM	0.1MF 5% 50V
C931	1-136-169-00	FILM	0.22MF 5% 50V
C932	1-137-399-11	FILM	0.1MF 5% 50V
C933	1-126-934-11	ELECT	220MF 20% 16V
C934	1-126-961-11	ELECT	2.2MF 20% 50V
C935	1-136-169-00	FILM	0.22MF 5% 50V
C937	1-126-935-11	ELECT	470MF 20% 16V
C939	1-137-374-11	FILM	0.047MF 5% 50V
C940	1-137-374-11	FILM	0.047MF 5% 50V
C941	1-136-169-00	FILM	0.22MF 5% 50V
C942	1-126-926-11	ELECT	1000MF 20% 10V
C943	1-137-372-11	FILM	0.022MF 5% 50V
C944	1-137-366-11	FILM	0.0022MF 5% 50V
C945	1-137-372-11	FILM	0.022MF 5% 50V
C946	1-102-106-00	CERAMIC	100PF 10% 50V
C948	1-137-399-11	FILM	0.1MF 5% 50V
C950	1-117-378-91	FILM	1MF 5% 50V
C955	1-102-106-00	CERAMIC	100PF 10% 50V
C960	1-136-177-00	FILM	1MF 5% 50V
C961	1-137-399-11	FILM	0.1MF 5% 50V
C962	1-137-399-11	FILM	0.1MF 5% 50V
C963	1-137-399-11	FILM	0.1MF 5% 50V
C967	1-102-106-00	CERAMIC	100PF 10% 50V
C968	1-126-960-11	ELECT	1MF 20% 50V
C969	1-137-364-11	FILM	0.001MF 5% 50V
C970	1-102-106-00	CERAMIC	100PF 10% 50V

REF.NO.	PART NO.	DESCRIPTION	REMARK
C1801	1-102-112-00	CERAMIC	330PF 10% 50V
C1802	1-102-112-00	CERAMIC	330PF 10% 50V
C1803	1-136-169-00	FILM	0.22MF 5% 50V
CONNECTOR			
CN501 *	1-580-798-11	CONNECTOR PIN (DY) 6P	
CN503 *	1-900-801-16	CONNECTOR ASSY, 2P BOARD IN	
CN504	1-695-915-11	TAB (CONTACT)	
CN505	1-564-513-11	PLUG, CONNECTOR 10P	
CN508 *	1-564-514-11	PLUG, CONNECTOR 11P	
CN509 *	1-508-879-11	BASE POST	
CN511	1-564-511-11	PLUG, CONNECTOR 8P	
CN512	1-695-915-11	TAB (CONTACT)	
CN600 Δ	1-251-227-11	INLET, AC	
CN601	1-691-960-11	PIN, CONNECTOR (PC BOARD) 3P	
CN605 *	1-506-371-00	PIN, CONNECTOR 2P	
CN610	1-695-915-11	TAB (CONTACT)	
DIODE			
D401	8-719-010-34	DIODE UZ-4.7BSC	
D402	8-719-979-58	DIODE EGP10D	
D403	8-719-908-03	DIODE GP08D	
D501	8-719-061-21	DIODE FMQ-G5FMS	
D502	8-719-110-49	DIODE RD18ESB2	
D503	8-719-911-19	DIODE 1SS119-25	
D504	8-719-051-97	DIODE 3DL41A(LC6-15)	
D505	8-719-110-17	DIODE RD10ESB2	
D506	8-719-110-67	DIODE RD27ESB2	
D508	8-719-975-77	DIODE SB340	
D509	8-719-979-58	DIODE EGP10D	
D510	8-719-979-58	DIODE EGP10D	
D511 Δ	8-719-110-67	DIODE RD27ESB2	
D515	8-719-979-58	DIODE EGP10D	
D522	8-719-911-19	DIODE 1SS119-25	
D526	8-719-018-82	DIODE RGP02-20EL-6394	
D534	8-719-911-55	DIODE U05G	
D544	8-719-979-58	DIODE EGP10D	
D595	8-719-911-19	DIODE 1SS119-25	
D596	8-719-911-19	DIODE 1SS119-25	
D598	8-719-110-49	DIODE RD18ESB2	
D601 Δ	8-719-025-88	DIODE GBU4JL-6088	
D602	8-719-970-83	DIODE HSS82	
D603	8-719-110-49	DIODE RD18ESB2	
D604	8-719-053-19	DIODE UF4007G23	
D605	8-719-970-83	DIODE HSS82	
D607	8-719-979-58	DIODE EGP10D	
D608	8-719-986-73	DIODE RB441Q	
D609	8-719-982-03	DIODE MTZJ-3.6A	



Note: The components identified by shading and mark Δ are critical for safety. Replace only with part number specified.

Note: Les composants identifiés par un trame et une marque Δ sont critiques pour la sécurité. Ne les remplacer que par une pièce portant le numéro spécifié.

REF.NO.	PART NO.	DESCRIPTION	REMARK
D650	8-719-048-62	DIODE UF3ML-6505	
D651	8-719-979-58	DIODE EGP10D	
D652	8-719-979-50	DIODE EGP30D	
D653	8-719-979-84	DIODE EGP20DPKG23	
D654	8-719-051-97	DIODE 3DL41A(LC6-15)	
D670	8-719-911-19	DIODE 1SS119-25	
D801	8-719-911-19	DIODE 1SS119-25	
D903	8-719-970-83	DIODE HSS82	
D906	8-719-109-89	DIODE RD5.6ESB2	
D907	8-719-109-89	DIODE RD5.6ESB2	
D908	8-719-911-19	DIODE 1SS119-25	
D909	8-719-109-89	DIODE RD5.6ESB2	
D910	8-719-911-19	DIODE 1SS119-25	
D913	8-719-067-04	DIODE LT2463-23	
D915	8-719-911-19	DIODE 1SS119-25	
D916	8-719-911-19	DIODE 1SS119-25	
D917	8-719-911-19	DIODE 1SS119-25	
D918	8-719-911-19	DIODE 1SS119-25	
D920	8-719-010-34	DIODE UZ-4.7BSC	
D921	8-719-911-19	DIODE 1SS119-25	
D922	8-719-911-19	DIODE 1SS119-25	
D923	8-719-911-19	DIODE 1SS119-25	
D924	8-719-911-19	DIODE 1SS119-25	
D944	8-719-911-19	DIODE 1SS119-25	
D945	8-719-911-19	DIODE 1SS119-25	
D946	8-719-911-19	DIODE 1SS119-25	
<u>FUSE</u>			
F601 Δ	1-576-231-11	FUSE (H.B.C.) 4A/250V	
<u>FERRITE BEAD</u>			
FB501	1-410-396-41	INDUCTOR	0.45UH
FB502	1-412-911-11	INDUCTOR	
FB503	1-412-911-11	INDUCTOR	
FB524	1-412-911-11	INDUCTOR	
FB525	1-412-911-11	INDUCTOR	
FB601	1-412-911-11	INDUCTOR	
FB602	1-412-911-11	INDUCTOR	
FB603	1-412-911-11	INDUCTOR	
FB604	1-412-911-11	INDUCTOR	
FB605	1-412-911-11	INDUCTOR	
FB606	1-412-911-11	INDUCTOR	
FB607	1-412-911-11	INDUCTOR	
FB608 Δ	1-412-911-11	INDUCTOR	
FB609 Δ	1-412-911-11	INDUCTOR	
FB610 Δ	1-412-911-11	INDUCTOR	
FB611 Δ	1-412-911-11	INDUCTOR	
FB612 Δ	1-412-911-11	INDUCTOR	

REF.NO.	PART NO.	DESCRIPTION	REMARK
FB613 Δ	1-412-911-11	INDUCTOR	
FB614 Δ	1-412-911-11	INDUCTOR	
FB615 Δ	1-412-911-11	INDUCTOR	
FB901	1-412-911-11	INDUCTOR	
FB902	1-412-911-11	INDUCTOR	
FB903	1-412-911-11	INDUCTOR	
FB904	1-412-911-11	INDUCTOR	
FB905	1-412-911-11	INDUCTOR	
<u>TERMINAL</u>			
GT001 *	1-537-738-21	TERMINAL, EARTH	
GT002 *	1-537-738-21	TERMINAL, EARTH	
<u>IC</u>			
IC400	8-759-803-42	IC LA6500-FA	
IC401	8-759-980-58	IC TDA8172	
IC601 Δ	8-759-399-81	IC MC44603P	
IC603 Δ	8-749-012-59	IC MOC8105TV	
IC604 Δ	8-759-072-98	IC TDA8138A	
IC652 Δ	8-759-466-13	IC TL431ACLPRP	
IC801 Δ	8-759-466-15	IC UPC6753	
IC901	8-759-399-80	IC ST7272N5B1/CKO	
IC902 Δ	8-759-269-04	IC SN74HCT02AN	
IC903	8-759-165-81	IC PST600D-T	
IC904 Δ	8-759-399-77	IC TDA9105	
<u>COIL</u>			
L501	1-412-550-11	INDUCTOR	1.2MMH
L504	1-459-104-00	COIL, WITH CORE	
L505	1-412-531-31	INDUCTOR	33UH
L506	1-459-104-00	COIL, WITH CORE	
L507	1-412-531-31	INDUCTOR	33UH
L513	1-409-896-11	COIL, HORIZONTAL LINEARITY	
L650	1-412-537-31	INDUCTOR	10
L651	1-412-537-31	INDUCTOR	10
L652	1-406-665-11	COIL, CHOKER	10
L653	1-412-537-31	INDUCTOR	10
L801	1-410-645-31	INDUCTOR	10
L900	1-410-645-31	INDUCTOR	10
<u>FILTER</u>			
LF601 Δ	1-429-180-11	TRANSFORMER, LINE FILTER	
<u>TRANSISTOR</u>			
Q500	8-729-031-89	TRANSISTOR 2SC3941A-Q(TA)	
Q501	8-729-119-76	TRANSISTOR 2SA1175-HFE	



Note: The components Identified by shading and mark Δ are critical for safety. Replace only with part number specified.

Note: Les composants identifiés per un trame et une marque Δ sont critiques pour la sécurité. Ne les remplacer que par une pièce portant le numéro spécifique.

REF.NO.	PART NO.	DESCRIPTION	REMARK
Q502 Δ	8-729-043-37	TRANSISTOR IRFU214	
Q503	8-729-027-97	TRANSISTOR IRFI9630G-LF	
Q504	8-729-119-78	TRANSISTOR 2SC2785-HFE	
Q505	8-729-119-76	TRANSISTOR 2SA1175-HFE	
Q507	8-729-027-95	TRANSISTOR 2SC5129(LBSONY)	
Q508 Δ	8-729-042-24	TRANSISTOR 2SB949-LE	
Q509 Δ	8-729-042-33	TRANSISTOR 2SD1275Q-LE	
Q510	8-729-027-82	TRANSISTOR IRFPE40LF20	
	4-047-285-01	SHEET, INSULATING	
Q512	8-729-087-14	TRANSISTOR 2SK1904	
Q513	8-729-027-14	TRANSISTOR 2SK1904	
Q514	8-729-027-14	TRANSISTOR 2SK1904	
Q515	8-729-140-50	TRANSISTOR 2SC3209LK	
Q528	8-729-140-50	TRANSISTOR 2SC3209LK	
Q529	8-729-028-34	TRANSISTOR 2SD1640Q,R	
Q602	8-729-926-79	TRANSISTOR IRFIBC40	
Q654	8-729-141-83	TRANSISTOR 2SB1094-LK	
Q655	8-729-119-78	TRANSISTOR 2SC2785-HFE	
Q656 Δ	8-729-119-78	TRANSISTOR 2SC2785-HFE	
Q670	8-729-142-46	TRANSISTOR 2SC2001-LK	
Q901	8-729-119-78	TRANSISTOR 2SC2785-HFE	
Q902	8-729-029-86	TRANSISTOR DTC124ESA	
Q903	8-729-107-78	TRANSISTOR 2SC3623-K	
RESISTOR			
R401	1-249-425-11	CARBON	4.7K 5% 1/4W
R407	1-215-447-00	METAL	12K 1% 1/4W
R408	1-249-383-11	CARBON	1.5 5% 1/4W F
R410	1-215-859-00	METAL OXIDE	22 5% 1W F
R411	1-215-445-00	METAL	10K 1% 1/4W
R412	1-215-421-00	METAL	1K 1% 1/4W
R418	1-214-798-21	METAL	1.8 1% 1/2W
R421	1-214-800-11	METAL	2.2 1% 1/2W
R422	1-215-866-11	METAL OXIDE	330 5% 1W F
R423	1-215-439-00	METAL	5.6K 1% 1/4W
R424	1-215-447-00	METAL	12K 1% 1/4W
R425	1-215-439-00	METAL	5.6K 1% 1/4W
R426	1-249-383-11	CARBON	1.5 5% 1/4W F
R427	1-215-447-00	METAL	12K 1% 1/4W
R500	1-249-405-11	CARBON	100 5% 1/4W F
R501	1-247-863-91	CARBON	22K 5% 1/4W
R503	1-249-437-11	CARBON	47K 5% 1/4W
R504	1-215-888-00	METAL OXIDE	220 5% 2W F
R505	1-247-863-91	CARBON	22K 5% 1/4W
R506	1-216-392-11	METAL OXIDE	1.8 5% 3W F
R507	1-249-437-11	CARBON	47K 5% 1/4W
R508	1-216-392-11	METAL OXIDE	1.8 5% 3W F
R509	1-249-389-11	CARBON	4.7 5% 1/4W F

REF.NO.	PART NO.	DESCRIPTION	REMARK
R510	1-249-389-11	CARBON	4.7 5% 1/4W
R511	1-249-401-11	CARBON	47 5% 1/4W
R512	1-247-881-00	CARBON	120K 5% 1/4W
R513	1-249-429-11	CARBON	10K 5% 1/4W
R514	1-249-429-11	CARBON	10K 5% 1/4W
R515	1-215-485-00	METAL	470K 1% 1/4W
R516	1-219-683-11	METAL	220K 5% 1/2W
R517	1-249-417-11	CARBON	1K 5% 1/4W F
R518	1-249-417-11	CARBON	1K 5% 1/4W F
R519	1-249-437-11	CARBON	47K 5% 1/4W
R520	1-249-417-11	CARBON	1K 5% 1/4W F
R521	1-249-389-11	CARBON	4.7 5% 1/4W F
R522	1-249-417-11	CARBON	1K 5% 1/4W F
R523	1-249-377-11	CARBON	0.47 5% 1/4W F
R524	1-216-447-00	METAL OXIDE	27 5% 2W F
R525	1-249-426-11	CARBON	5.6K 5% 1/4W
R526	1-249-377-11	CARBON	0.47 5% 1/4W F
R527	1-216-477-11	METAL OXIDE	270 5% 3W F
R528	1-215-910-00	METAL OXIDE	68 5% 3W F
R529	1-249-441-11	CARBON	100K 5% 1/4W
R530	1-216-474-11	METAL OXIDE	82 5% 3W F
R531	1-216-474-11	METAL OXIDE	82 5% 3W F
R532	1-249-389-11	CARBON	4.7 5% 1/4W F
R533 Δ	1-215-487-00	METAL	560K 1% 1/4W
R534 Δ	1-215-467-00	METAL	82K 1% 1/4W
R535 Δ	1-215-469-00	METAL	100K 1% 1/4W
R536	1-249-428-11	CARBON	8.2K 5% 1/4W
R537	1-249-397-11	CARBON	22 5% 1/4W F
R538	1-215-421-00	METAL	1K 1% 1/4W
R539	1-215-476-00	METAL	200K 1% 1/4W
R540	1-215-469-00	METAL	100K 1% 1/4W
R541	1-215-493-00	METAL	1M 1% 1/4W
R542 Δ	1-215-429-00	METAL	2.2K 1% 1/4W
R543 Δ	1-215-429-00	METAL	2.2K 1% 1/4W
R544 Δ	1-215-463-00	METAL	56K 1% 1/4W
R545 Δ	1-215-461-00	METAL	47K 1% 1/4W
R546	1-249-397-11	CARBON	22 5% 1/4W F
R547	1-247-807-31	CARBON	100 5% 1/4W
R548	1-215-433-00	METAL	3.3K 1% 1/4W
R549	1-215-880-00	METAL OXIDE	10 5% 2W F
R550	1-249-429-11	CARBON	10K 5% 1/4W
R551	1-215-423-00	METAL	1.2K 1% 1/4W
R552	1-249-385-11	CARBON	2.2 5% 1/4W F
R553	1-249-421-11	CARBON	2.2K 5% 1/4W
R554	1-249-421-11	CARBON	2.2K 5% 1/4W
R555	1-249-377-11	CARBON	0.47 5% 1/4W F
R563	1-249-421-11	CARBON	2.2K 5% 1/4W
R564	1-249-421-11	CARBON	2.2K 5% 1/4W



Note: The components identified by shading and mark Δ are critical for safety. Replace only with part number specified.

Note: Les composants identifiés par un trame et une marque Δ sont critiques pour la sécurité. Ne les remplacer que par une pièce portant le numéro spécifié.

REF.NO.	PART NO.	DESCRIPTION	REMARK
R567	1-215-880-00	METAL OXIDE	10 5% 2W F
R601 Δ	1-202-847-00	SOLID	560K 20% 1/2W
R602 Δ	1-205-998-11	WIREWOUND	1 5% 10W
R603 Δ	1-202-933-61	FUSIBLE	0.1 10% 1/2W F
R604	1-215-926-00	METAL OXIDE	33K 5% 3W F
R605	1-249-437-11	CARBON	47K 5% 1/4W
R606	1-249-417-11	CARBON	1K 5% 1/4W
R607	1-247-791-91	CARBON	22 5% 1/4W
R608	1-249-429-11	CARBON	10K 5% 1/4W
R609	1-216-381-11	METAL OXIDE	0.22 5% 3W F
R610	1-215-925-11	METAL OXIDE	22K 5% 3W F
R611	1-247-885-00	CARBON	180K 5% 1/4W
R612	1-249-431-11	CARBON	15K 5% 1/4W
R613	1-249-411-11	CARBON	330 5% 1/4W
R614	1-249-421-11	CARBON	2.2K 5% 1/4W
R615	1-249-377-11	CARBON	0.47 5% 1/4W F
R619	1-249-425-11	CARBON	4.7K 5% 1/4W
R621	1-249-434-11	CARBON	27K 5% 1/4W
R623	1-215-445-00	METAL	10K 1% 1/4W
R631	1-215-405-00	METAL	220 1% 1/4W
R651	1-215-878-00	METAL OXIDE	33K 5% 1W F
R652 Δ	1-211-874-11	FUSIBLE	0.12 10% 1/2W
R654 Δ	1-219-154-11	FUSIBLE	0.12 10% 1/4W
R655	1-249-417-11	CARBON	1K 5% 1/4W
R656	1-249-417-11	CARBON	1K 5% 1/4W
R657	1-249-429-11	CARBON	10K 5% 1/4W
R658	1-215-417-00	METAL	680 1% 1/4W
R659	1-215-483-00	METAL	390K 1% 1/4W
R660	1-215-443-00	METAL	8.2K 1% 1/4W
R661	1-247-895-91	CARBON	470K 5% 1/4W
R662	1-215-459-00	METAL	39K 1% 1/4W
R663	1-249-429-11	CARBON	10K 5% 1/4W
R664	1-216-349-00	METAL OXIDE	1 5% 1W F
R665	1-249-429-11	CARBON	10K 5% 1/4W
R666	1-249-429-11	CARBON	10K 5% 1/4W
R667 Δ	1-211-881-11	FUSIBLE	0.47 10% 1/2W
R670	1-249-417-11	CARBON	1K 5% 1/4W
R671	1-249-417-11	CARBON	1K 5% 1/4W
R672	1-249-403-11	CARBON	68 5% 1/4W
R673	1-249-429-11	CARBON	10K 5% 1/4W
R674	1-249-429-11	CARBON	10K 5% 1/4W
R801	1-249-377-11	CARBON	0.47 5% 1/4W F
R807	1-249-438-11	CARBON	56K 5% 1/4W
R808	1-215-485-00	METAL	470K 1% 1/4W
R809	1-215-483-00	METAL	390K 1% 1/4W
R811	1-249-432-11	CARBON	18K 5% 1/4W
R815	1-215-457-00	METAL	33K 1% 1/4W
R817	1-215-461-00	METAL	47K 1% 1/4W

REF.NO.	PART NO.	DESCRIPTION	REMARK
R819	1-215-457-00	METAL	33K 1% 1/4W
R820	1-215-455-00	METAL	27K 1% 1/4W
R821	1-215-465-00	METAL	68K 1% 1/4W
R822	1-215-469-00	METAL	100K 1% 1/4W
R823	1-215-477-00	METAL	220K 1% 1/4W
R824	1-249-429-11	CARBON	10K 5% 1/4W
R830	1-215-461-00	METAL	47K 1% 1/4W
R831	1-215-405-00	METAL	220 1% 1/4W
R900	1-249-417-11	CARBON	1K 5% 1/4W
R901	1-249-425-11	CARBON	4.7K 5% 1/4W
R902	1-249-425-11	CARBON	4.7K 5% 1/4W
R903	1-249-425-11	CARBON	4.7K 5% 1/4W
R904	1-249-425-11	CARBON	4.7K 5% 1/4W
R905	1-249-425-11	CARBON	4.7K 5% 1/4W
R906	1-215-449-00	METAL	15K 1% 1/4W
R907	1-249-417-11	CARBON	1K 5% 1/4W
R908	1-249-425-11	CARBON	4.7K 5% 1/4W
R909	1-249-437-11	CARBON	47K 5% 1/4W
R910	1-247-895-91	CARBON	470K 5% 1/4W
R911	1-249-431-11	CARBON	15K 5% 1/4W
R912	1-249-413-11	CARBON	470 5% 1/4W
R915	1-249-417-11	CARBON	1K 5% 1/4W
R916	1-249-417-11	CARBON	1K 5% 1/4W
R917	1-249-417-11	CARBON	1K 5% 1/4W
R918	1-249-435-11	CARBON	33K 5% 1/4W
R919	1-249-425-11	CARBON	4.7K 5% 1/4W
R920	1-249-417-11	CARBON	1K 5% 1/4W
R921	1-247-863-91	CARBON	22K 5% 1/4W
R924	1-249-434-11	CARBON	27K 5% 1/4W
R925	1-249-432-11	CARBON	18K 5% 1/4W
R926	1-249-434-11	CARBON	27K 5% 1/4W
R927	1-249-434-11	CARBON	27K 5% 1/4W
R928	1-249-434-11	CARBON	27K 5% 1/4W
R929	1-249-436-11	CARBON	39K 5% 1/4W
R930	1-249-434-11	CARBON	27K 5% 1/4W
R931	1-249-428-11	CARBON	8.2K 5% 1/4W
R932	1-249-428-11	CARBON	8.2K 5% 1/4W
R933	1-249-431-11	CARBON	15K 5% 1/4W
R934	1-249-429-11	CARBON	10K 5% 1/4W
R935	1-249-428-11	CARBON	8.2K 5% 1/4W
R936	1-249-425-11	CARBON	4.7K 5% 1/4W
R937	1-249-428-11	CARBON	8.2K 5% 1/4W
R938	1-249-428-11	CARBON	8.2K 5% 1/4W
R939	1-249-417-11	CARBON	1K 5% 1/4W
R940	1-249-434-11	CARBON	27K 5% 1/4W
R941	1-249-428-11	CARBON	8.2K 5% 1/4W
R942	1-249-434-11	CARBON	27K 5% 1/4W
R943	1-249-428-11	CARBON	8.2K 5% 1/4W



Note: The components identified by shading and mark **△** are critical for safety. Replace only with part number specified.

Note: The components identified by **☒** in this manual have been carefully factory-selected for each set in order to satisfy regulations regarding X-ray radiation. Should replacement be required, replace only with the value originally used.

REF.NO.	PART NO.	DESCRIPTION	REMARK
R944	1-249-424-11	CARBON	3.9K 5% 1/4W
R945	1-249-424-11	CARBON	3.9K 5% 1/4W
R946	1-247-903-00	CARBON	1M 5% 1/4W
R947	1-247-883-00	CARBON	150K 5% 1/4W
R948	1-247-883-00	CARBON	150K 5% 1/4W
R949	1-247-883-00	CARBON	150K 5% 1/4W
R950	1-247-883-00	CARBON	150K 5% 1/4W
R951	1-247-883-00	CARBON	150K 5% 1/4W
R952	1-247-883-00	CARBON	150K 5% 1/4W
R954	1-249-425-11	CARBON	4.7K 5% 1/4W
R956	1-249-421-11	CARBON	2.2K 5% 1/4W
R957	1-215-441-00	METAL	6.8K 1% 1/4W
R958	1-249-420-11	CARBON	1.8K 5% 1/4W
R959	1-249-428-11	CARBON	8.2K 5% 1/4W
R960	1-249-425-11	CARBON	4.7K 5% 1/4W
R962	1-249-429-11	CARBON	10K 5% 1/4W
R963	1-249-429-11	CARBON	10K 5% 1/4W
R964	1-247-883-00	CARBON	150K 5% 1/4W
R965	1-249-415-11	CARBON	680 5% 1/4W
R966	1-247-895-91	CARBON	470K 5% 1/4W
R968	1-247-883-00	CARBON	150K 5% 1/4W
R972	1-249-429-11	CARBON	10K 5% 1/4W
R973	1-249-429-11	CARBON	10K 5% 1/4W
R975	1-249-429-11	CARBON	10K 5% 1/4W
R976	1-249-425-11	CARBON	4.7K 5% 1/4W
R977	1-249-417-11	CARBON	1K 5% 1/4W
R979	1-249-432-11	CARBON	18K 5% 1/4W
R980	1-247-883-00	CARBON	150K 5% 1/4W
R981	1-249-413-11	CARBON	470 5% 1/4W
R983	1-215-467-00	METAL	82K 1% 1/4W
R984	1-249-417-11	CARBON	1K 5% 1/4W
R985	1-247-807-31	CARBON	100 5% 1/4W
R986	1-215-445-00	METAL	10K 1% 1/4W
R987	1-249-425-11	CARBON	4.7K 5% 1/4W
R989	1-249-429-11	CARBON	10K 5% 1/4W
R990	1-247-807-31	CARBON	100 5% 1/4W
R991	1-247-807-31	CARBON	100 5% 1/4W
R992	1-249-417-11	CARBON	1K 5% 1/4W
R993	1-249-429-11	CARBON	10K 5% 1/4W
R994	1-249-417-11	CARBON	1K 5% 1/4W
R995	1-249-413-11	CARBON	470 5% 1/4W
R996	1-249-429-11	CARBON	10K 5% 1/4W
R997	1-249-417-11	CARBON	1K 5% 1/4W
R998	1-249-429-11	CARBON	10K 5% 1/4W
R999	1-249-413-11	CARBON	470 5% 1/4W
R1801	1-215-433-00	METAL	3.3K 1% 1/4W
R1806	1-215-421-00	METAL	1K 1% 1/4W
R1810	1-215-413-00	METAL	470 1% 1/4W

REF.NO.	PART NO.	DESCRIPTION	REMARK
R1811	1-215-409-00	METAL	330 1% 1/4W
R1812	1-215-413-00	METAL	470 1% 1/4W
R1813	1-215-413-00	METAL	470 1% 1/4W
R1814	1-215-417-00	METAL	680 1% 1/4W
R1815	1-215-469-00	METAL	100K 1% 1/4W
R1818	1-215-425-00	METAL	1.5K 1% 1/4W
R1819	1-215-425-00	METAL	1.5K 1% 1/4W
R1820	1-215-433-00	METAL	3.3K 1% 1/4W
R1822	1-215-433-00	METAL	3.3K 1% 1/4W
R1823	1-215-413-00	METAL	470 1% 1/4W
R1832	1-215-469-00	METAL	100K 1% 1/4W
VARIABLE RESISTOR			
☒ RV501 △	1-241-767-21	RES, ADJ, CERMET 100K	
	4-060-176-01	COVER, VOLUME 6 MOLD	
RELAY			
RY601 △	1-755-031-11	RELAY	
SWITCH			
S1801	1-692-431-21	SWITCH, TACTILE	
S1802	1-692-431-21	SWITCH, TACTILE	
S1803	1-692-431-21	SWITCH, TACTILE	
S1809	1-692-431-21	SWITCH, TACTILE	
S1815	1-692-220-11	SWITCH, TACTILE	
S1816	1-692-220-11	SWITCH, TACTILE	
S1817	1-692-220-11	SWITCH, TACTILE	
S1818	1-692-220-11	SWITCH, TACTILE	
S1821	1-692-431-21	SWITCH, TACTILE	
SPARK GAP			
SG501 △	1-519-422-11	GAP, SPARK	
TRANSFORMER			
T501 △	X-4033-083-1	TRANSFORMER ASSY, FLYBACK (NX-4130//J1E)	
T503	1-429-109-11	TRANSFORMER, FERRITE (DFT)	
T504 △	1-431-248-11	TRANSFORMER, FERRITE (HDT)	
T505	1-429-211-11	TRANSFORMER, FERRITE (HST)	
T601 △	1-431-247-11	TRANSFORMER, CONVERTER (SRT)	
THERMISTOR			
TH501	1-807-796-11	THERMISTOR	
TH601 △	1-809-260-11	THERMISTOR, POWER	
TH602 △	1-809-827-11	THERMISTOR, POSITIVE	
CRYSTAL			
X900	1-567-890-11	VIBRATOR, CRYSTAL	

Note: The components identified by shading and mark Δ are critical for safety. Replace only with part number specified.

Note: Les composants identifiés par un trame et une marque Δ sont critiques pour la sécurité. Ne les remplacer que par une pièce portant le numéro spécifié.

<u>REF.NO.</u>	<u>PART NO.</u>	<u>DESCRIPTION</u>	<u>REMARK</u>
<u>MISCELLANEOUS</u>			
Δ	1-409-799-11	COIL, DEMAGNETIC	
Δ	1-452-756-11	NECK ASSY (NA293)	
	1-500-386-11	FILTER, CLAMP (FERRITE CORE)	
Δ	1-765-717-11	CORD SET, POWER (EQ)	
Δ	1-558-481-11	CORD SET, POWER (SH)	
	1-543-653-11	CORE ASSY, BEAD (DIVISION TYPE)	
	4-060-155-01	HOLDER, HV CABLE	
Δ	8-451-469-21	DY Y15FRF2M2	
Δ	8-734-827-05	CRT 15FR2 (M36LDJ15X) (EQ)	
Δ	8-734-829-05	CRT 15FR2 (M36LDJ15X) (SH)	
*	3-860-654-01	MANUAL, INSTRUCTION	
Δ	X-4033-083-1	TRANSFORMER ASSY, FLYBACK (NX-4130/J1E)	